



# FlightMax<sup>®</sup>

**EX500-Series MFD**

## **Installation Manual**

P/N 600-00079-000  
Rev 06

## Table of Contents

<b>1. GENERAL INFORMATION .....</b>	<b>4</b>
1.1. EQUIPMENT DESCRIPTION .....	5
1.2. TECHNICAL SPECIFICATIONS.....	5
<b>2. INSTALLATION INSTRUCTIONS.....</b>	<b>6</b>
2.1. UNPACKING AND INSPECTION .....	6
2.2. FLIGHTMAX EX500 MFD INSTALLATION .....	7
2.2.1. <i>EX500 Installation Considerations</i> .....	7
2.2.2. <i>Location and Viewing Angle</i> .....	7
2.2.3. <i>Positioning and Mounting the EX500 Tray</i> .....	8
2.2.4. <i>Electrical and Sensor Interface Wiring</i> .....	9
2.2.5. <i>Electrical Load Analysis</i> .....	10
2.3. DATALINK ANTENNA INSTALLATION CONSIDERATIONS.....	10
2.3.1. <i>Narrowcast Antenna Details</i> .....	10
2.3.2. <i>Broadcast Antenna Details</i> .....	11
2.3.3. <i>Weight and Balance</i> .....	11
<b>3. POST INSTALLATION CONFIGURATION GUIDE.....</b>	<b>12</b>
3.1. SYSTEM CONFIGURATION .....	12
3.1.1. <i>Entering The Maintenance Mode</i> .....	12
3.2. EX500 SENSOR INTERFACE SETUP .....	13
3.2.1. <i>EX500 Sensor Interface Provisioning Confirmation</i> .....	13
3.2.2. <i>Configuration Options</i> .....	13
3.2.3. <i>Configuration Selection</i> .....	19
3.3. GPS/FMS SYSTEM SETUP.....	20
3.4. TRAFFIC SYSTEM SETUP.....	20
3.5. LIGHTNING SYSTEM SETUP.....	22
3.6. RADAR SYSTEM SETUP .....	23
3.6.1. <i>RADAR System Calibration</i> .....	26
3.6.2. <i>Roll Trim Adjustment</i> .....	30
3.7. TAWS SYSTEM SETUP.....	30
3.8. NARROWCAST DATALINK SETUP .....	30
3.9. BROADCAST DATALINK SETUP.....	31
3.10. MAP HEADING SOURCE SETUP.....	31
3.11. BEZEL KEY DIMMING SETUP .....	33
3.12. SYSTEM INFORMATION .....	34
<b>4. EX500 MFD CHECKOUT.....</b>	<b>35</b>
4.1. INITIAL INSTALLATION VALIDATION TEST.....	35
4.2. SENSOR COMMUNICATIONS CHECKOUT.....	36
4.2.1. <i>GPS/FMS Checkout</i> .....	36
4.2.2. <i>Lightning Sensor Checkout</i> .....	37
4.2.3. <i>Traffic Sensor Checkout</i> .....	38
4.2.4. <i>TAWS Checkout</i> .....	40
4.2.5. <i>RADAR Checkout</i> .....	41
4.2.6. <i>Narrowcast Datalink Checkout</i> .....	42
4.2.7. <i>Broadcast Datalink Checkout</i> .....	45
4.2.8. <i>Broadcast Datalink Satellite Reception Confirmation</i> .....	45
4.2.9. <i>Synchro Heading Checkout</i> .....	46
4.3. POST INSTALLATION CHECK EMI CHECK.....	47
<b>5. MFD DATA UPDATES .....</b>	<b>48</b>

5.1. MAP NAVDATA DATABASE UPDATES.....	48
5.1.1. To perform a data update .....	48
5.2. CHART DATABASE UPDATES.....	48
5.2.1. To perform a chart data update .....	49
<b>6. FACTORY SERVICE POLICIES.....</b>	<b>50</b>
6.1. TECHNICAL SUPPORT.....	50
6.2. GENERAL SERVICE PROCEDURES.....	50
6.3. AC 20-68B RECOMMENDED RADIATION SAFETY.....	50
APPENDIX A ENVIRONMENTAL QUALIFICATION FORMS .....	52
APPENDIX B STC EX500 PERMISSION .....	53
APPENDIX C INSTALLATION MECHANICAL: MFD, TRAY & PANEL DIMENSIONS .....	54
APPENDIX D INSTALLATION MECHANICAL: TRAY SUPPORT STRUCTURE PANEL.....	56
APPENDIX E INSTALLATION MECHANICAL: NARROWCAST DATALINK ANTENNA .....	57
APPENDIX F EX500 WIRING: GENERAL .....	58
APPENDIX G EX500 WIRING: GPS/FMS SUB-SYSTEM.....	59
APPENDIX H EX500 WIRING: LIGHTNING AND BROADCAST DATALINK SENSORS .....	60
APPENDIX I EX500 WIRING: TRAFFIC SENSORS.....	61
APPENDIX J EX500 WIRING: TRAFFIC/TAWS SENSORS.....	62
APPENDIX K EX500 WIRING: DIGITAL RADAR.....	63
APPENDIX L EX500 WIRING: RDR-130/150/160 RADAR DIRECT CONNECT.....	64
APPENDIX M EX500 WIRING: RDR-130/150/160 RADAR W/ ADAPTOR CABLE .....	65
APPENDIX N EX500 WIRING: RDR-1100/1200 RADAR DIRECT CONNECT .....	66
APPENDIX O EX500 WIRING: RDR-1100/1200 RADAR W/ ADAPTOR CABLE.....	67
APPENDIX P EX500 WIRING: RDR-1300 RADAR DIRECT CONNECT .....	68
APPENDIX Q EX500 WIRING: RDR-1300 RADAR W/ ADAPTOR CABLE.....	69
APPENDIX R EX500 WIRING: WXR250/270/300 RADAR W/ ADAPTOR CABLE .....	70

## Table of Figures

Figure 1: Sample EX500 Panel Placements .....	7
Figure 2: Maintenance Mode Main Page (actual view depends on installed options).....	12
Figure 3: Maintenance Mode Sensor Support.....	13
Figure 4 Main Connector (P2) Pin Assignments.....	15
Figure 5 ARINC Port Pinout Cross-Reference .....	16
Figure 6 RS-232 Port Pinout Cross-Reference .....	17
Figure 7: Main Connector Port Assignments.....	18
Figure 8: GPS/FMS System Setup Page .....	19
Figure 9: Traffic System Setup Page .....	21
Figure 10: Lightning System Setup Page.....	23
Figure 11: Datalink Info Table.....	31
Figure 12: Map System Setup Page .....	32
Figure 13: Aircraft Setup Screen.....	33
Figure 14: Port Info Table .....	34
Figure 15: Platform Info Table .....	34
Figure 16: Start-up Screen .....	35

**The latest revision of the FlightMax EX500-Series MFD Installation Manual is made available to authorized Avidyne dealers on the web at [www.avidyne.com](http://www.avidyne.com).**

**Avidyne®, FlightMax® and FMX® are registered trademarks of Avidyne Corporation. Stormscope, and Skywatch® are registered trademarks of Goodrich.**



## 1. General Information

This manual contains information about the physical, mechanical, and electrical characteristics of the Avidyne FlightMax EX500-Series Multi-Function Display (MFD), and provides associated installation instructions. While installation of the FlightMax EX500 is straightforward, it is best to carefully devise a comprehensive installation strategy prior to commencing the installation effort. Follow the installation instructions carefully to obtain maximum performance from the FlightMax EX500 MFD.

This installation manual applies to Avidyne 700-00007-XXX-() EX500-Series MFD's with software listed in Section 2.1 of this manual.

MFD operating information is contained in the FlightMax EX500-Series MFD Pilot's Guide, Avidyne Manual 600-00078-000, which is supplied with the unit. It is recommended that avionics installers review the Pilot's Guide before operating the MFD. The most current version is available to installers on the web at [www.avidyne.com](http://www.avidyne.com).

The conditions and tests required for TSO approval of this article are minimum performance standards. It is the responsibility of those installing this article either on or within a specific type or class of aircraft to determine that the aircraft installation conditions are within the TSO standards. TSO articles must have separate approval for installation in aircraft. The article may be installed only if performed under 14 CFR part 43 or the applicable airworthiness requirements.

### **CAUTION:**

**AC 20-68B, Recommended Radiation Safety**, sets forth recommended radiation safety precautions to be taken by personnel when operating airborne weather radar on the ground. Dangers from ground operation of airborne weather radar include the possibility of human body damage and ignition of combustible material by radiated energy. The full text of this FAA Advisory Circular may be found on the web at [http://www1.faa.gov/RegulatoryAdvisory/ac\\_index.htm](http://www1.faa.gov/RegulatoryAdvisory/ac_index.htm).



### 1.1. Equipment Description

A complete FlightMax EX500-Series Multi-Function Display system consists of the following components:

- Avidyne FlightMax EX500-Series Multi-Function Display (MFD).
- System installation kit including MFD tray assembly, and necessary connectors.
- Optional radar interface cables connecting the MFD to the radar receiver/transmitter. These cables provide a simplified connection to the pre-existing wiring.
- User documentation including Pilot's Guide, Installation Manual, and Instructions for Continued Airworthiness.

### 1.2. Technical Specifications

<b>STANDARD FEATURES</b>	
Display	High Brightness Sunlight Readable Color AMLCD
Diagonal size	5.5 inches
Interfaces	RS-232, ARINC 429, ARINC 453, ARINC 407 & TTL
<b>PHYSICAL CHARACTERISTICS</b>	
Weight with tray	7.2 lbs
Height	4.35 inches (Face Plate)
Width	6.25 inches (Face Plate)
Depth	12.8 inches (Tray incl. Rear connectors)
Viewing Angle	Vertical: +30°, -10°
	Horizontal: 60° left and right of center
<b>OPERATING LIMITS</b>	
Voltage	18-32 VDC, negative ground
Current	Maximum: 5 A at 28V
See Appendix A for Environmental Qualification Form	



## 2. Installation Instructions

### 2.1. Unpacking and Inspection

The shipping carton of the FlightMax EX500, Avidyne P/N 850-00010-XXX contains the following components and parts:

Part Number	Qty	Description
700-00007-XXX	1	FlightMax EX500-Series Multi-Function Display
		-XXX Description
		-001 EX500, non-RADAR
		-002 EX500, RDR1100/1200
		-003 EX500, RDR1300
		-004 EX500, RDR130/150/160
		-005 EX500, RDS8X, RDR2XXX
-006 EX500, WXR250/270/300		
600-00078-000	1	FlightMax EX500-Series MFD Pilot's Guide.

The shipping carton of the FlightMax EX500 Installation Kit, Avidyne P/N 850-00011-000 contains the following components and parts:

Part Number	Qty	Description
700-00009-000	1	EX500 Tray Assembly
030-00181-000	1	Connector, D-Sub 78F, w/ backshell & Pins
150-00100-000	8	Screw, 4-40 x ¼ Flat, SS, 100 Degree
600-00079-000	1	FlightMax EX500-Series Multi-Function Display Installation Manual

Make sure that all the parts listed above were received and sustained no shipping damage. Where evidence of shipping damage exists, save the shipping carton and packing material to help substantiate your claim to the shipping company. Retain the original shipping carton and packing material in case you need to ship the unit for service.

Locate the labels on the bottom of the MFD. Verify that the MFD has the ordered feature option set marked on the label. During system checkout the installer will need to verify that one of the software revisions listed below (or later) is installed in the unit.

<b>Acceptable Software Revision Levels</b>	
Part Number	Revision
530-00163-000	00
530-00120-000	01

## 2.2. FlightMax EX500 MFD Installation

### 2.2.1. EX500 Installation Considerations

The EX500-Series MFD is intended for application as a supplementary situational awareness device. The EX500 contains software developed in accordance with RTCA/DO-178B Level D requirements.

### 2.2.2. Location and Viewing Angle

FlightMax EX500 is designed for panel mounting using the mounting tray supplied with the unit installation kit. Locate the MFD in a position on the panel where the pilot can easily reach the knobs and controls to operate and view it from the proper viewing angle.

<b>Viewing angle limits</b>	
Vertical	Up 30°, Down 10° [+30°/-10°]
Horizontal	Left and Right 60° [± 60°]

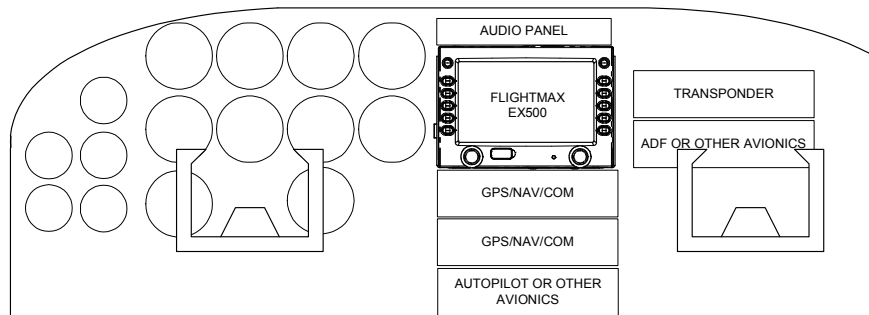

MFD PLACEMENT IN PANEL OF  
SMALLER AIRCRAFT (TYPICAL)

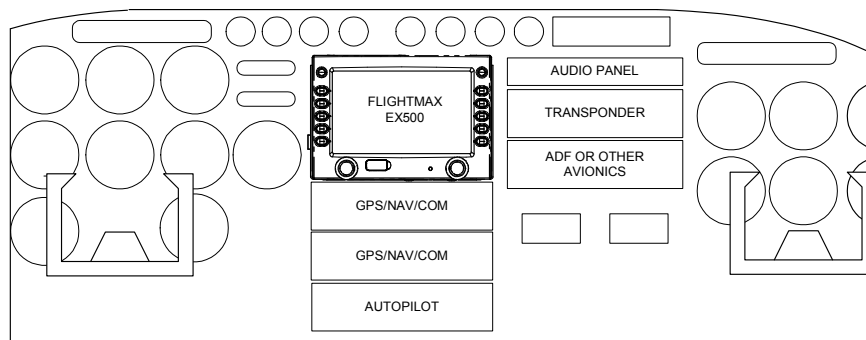

MFD PLACEMENT IN PANEL OF  
LARGER AIRCRAFT (TYPICAL)

**Figure 1: Sample EX500 Panel Placements**

#### 2.2.2.1. Cooling

The EX500 includes internal cooling provisions to maximize operational reliability. Care should be taken not to obstruct the air vents located at the rear and sides of the unit/tray assembly.

### 2.2.2.2. Heading Source Selection

The EX500 is capable of receiving aircraft heading from a variety of sources. Care should be taken when selecting which heading source is to be used in the system installation. Heading source options are listed below:

<u>Source</u>	<u>System</u>	<u>Interface</u>	<u>Source</u>	<u>System</u>	<u>Interface</u>
Synchro		ARINC 407 Synchro	GPS/FMS	GNC300XL	ARINC 429
Lightning	WX-500	RS-232		GPS 400/500	ARINC 429
Traffic	Skywatch	ARINC 429		GNS 430/530	ARINC 429
	Skywatch HP	ARINC 429		KLN-90B	ARINC 429
	KTA-870	ARINC 429		UNS-1B	ARINC 429
	KMH-880	ARINC 429		GNS-XLS	ARINC 429
	TCAS I	ARINC 429			

**Selection of the synchro option is recommended and yields the best system reliability (availability).** Heading information supplied by the other referenced systems is typically sourced from the synchro and may require interface converters between the synchro and the alternate heading source. Refer to manufacturer’s installation manuals for guidance. Failure of these alternate sources results in not only loss of that system but also heading related functionality on the EX500. Specifically, this results in the loss of RADAR overlay capability and forces NORTH UP display of other Map Mode data.

Refer to Appendix F and Section 3.9 of this document to select the active heading source.

### 2.2.3. Positioning and Mounting the EX500 Tray

As indicated in Section 2.2.2, the EX500 location may vary depending upon instrument panel size, control obstructions and other installed equipment. Four inches (4”) of clearance should be left behind the tray to allow for connector clearance and permit air circulation through the EX500. A minimum of 1/8” clearance between the tray and other avionics should be maintained for air circulation purposes. Avidyne mounting trays provide for a 0.125” clearance between the bezel and mounting tray (along the sides and top of the tray) to allow for any panel thickness. Ensure that the mounting tray is installed at the proper depth in the panel to allow the connectors of the EX500 to fully seat in the connectors of the mounting tray. When properly installed the EX500 bezel should make contact with the protruding lip on the bottom of the tray.

Structural aspects of the installation should be performed in accordance with AC43.13-2A, Chapter 1. Appendix D contains details on tray mounting and support.

When installed, the EX500 when operated with any combination of other installed avionics must not result in a deflection of the aircraft magnetic compass of greater than 10 degrees.

The entire back plate of the mounting tray may be removed (by removing the six screws which hold it in place) to facilitate wiring. Both the connectors and the back plate may be installed or removed when the tray is mounted in place. Complete system wiring per Section 2.2.4. With the wiring complete and the tray installed, follow the initial installation validation test procedure provided in Section 4.1 of this manual and proceed to the configuration instructions in Section 3 of this manual.



**CAUTION**

It is extremely important that the 0.125" panel thickness is not exceeded, or the EX500 may not fully seat in the mounting tray. If communication between the EX500 and any of the sensor interfaces is not established, ensure that the EX500 is fully seated in the tray, and then check all sensor connections.

#### 2.2.4. Electrical and Sensor Interface Wiring

Refer to Appendix F through Appendix R for system and sensor wiring diagrams. Wiring is to be performed in accordance with AC 43.13-1B. The following connectors, or equivalents, support the EX500 tray installation.

<i>Designation</i>	<i>Vendor</i>	<i>Part Number</i>	<i>Description</i>
P1	Positronic	DD44M10G00	44-Pin High Density Male D-Sub Connector
P2	Positronic	DD78F10G00	78-Pin High Density Female D-Sub Connector
J2	Delta Electronics	4205-018-N995	50 Ohm Blind Plug BNC Connector

The following notes apply to aircraft wiring to be used with the EX500 tray installation.

1. Power: P2- input: 5 A @ 28 vdc. Use 20 AWG for lengths greater than 3ft. Use 22 AWG for P2 high-density sockets. Circuit breaker: 7.5 amp recommended. For 14 vdc A/C, use 14 to 28 vdc converter (KGS Electronics RB-125, Ameri-King AK550-6 or similar with TSO-C71, output 5 A min. @ 28 vdc.)
2. Dimming: P2- input: use 22 AWG, connect to a/c instrument dimming bus. Supports any range 0-28 vdc. Connection to dimming-bus ground reference required.
3. ARINC 429: P2- wire: use 22 AWG twisted shielded pair, MS22759/18-22-2 or equivalent. Connect shield to P2 connector metallic backshell grounding screw with solder or crimp ring terminal.
4. ARINC 453: P2- wire: use 22 AWG twisted double shielded pair (Quadrax), (Bendix/King p/n 024-00064-0000) or equivalent. Connect outer shield to P2 connector metallic backshell grounding screw with solder or crimp terminal ring. Connect inner and outer shield to sensor connector metallic backshell grounding screw with solder or crimp terminal ring.
5. RS-232: P2- wire: use 22 AWG shielded triple, MS22759/18-22-3 or equivalent. Connect a dedicated RS-232 signal ground from the sensor to the MFD. Connect shield to P2 connector metallic backshell grounding screw with solder or crimp ring terminal.
6. Synchro input: P2- wire: use 22 AWG shielded double, MS22759/18-22-2 or equivalent, for REF HI and REF LO. Use 22 AWG shielded triple, MS27500/18-22-3 or equivalent, for X/Y/Z. Connect shield to P2 connector metallic backshell grounding screw with solder or crimp ring terminal.
7. Synchro Valid: Use 22 AWG shielded single, MS22759/18-22-1 or equivalent. Valid low is less than 1.4 vdc. Valid high is greater than 2.7vdc. Note: this input is optional. If not used, no connection is required. See Section 3.9 for configuration details.
8. Narrowcast Datalink antenna: J2- coax cable: use M17/128-RG400, (Thermax/CDT p/n RGS-400) high temperature, 50 ohm, stranded core with 0.038 o.d., or equivalent. Terminate antenna end with BNC series connector. See mechanical installation notes.

- 9. Analog radar: P1- control and data lines: Use 22 AWG shielded single, MS22759/18-22-1 or equivalent, for trigger and data lines. Use 22 AWG for all others. See wiring appendices for particular radar system wiring.
- 10. Shield terminations: Shield terminations to be made as close to the protected signal wire terminations as feasible.

### 2.2.5. Electrical Load Analysis

Prior to installation, an electrical load analysis should be performed specific to the aircraft. This analysis should be in accordance with AC 43.13-1B, Chapter 11. The following values may be used to support the analysis:

<i>Unit</i>	<i>28 VDC Nominal Load</i>	<i>28 VDC Maximum Load</i>
EX500	2 A	5 A

The power input to the EX500 should be circuit protected in accordance with the guidelines of AC 43.13-1B, Chapter 11, Section 2. A 7.5 amp circuit breaker is recommend for use with the EX500.

### 2.3. Datalink Antenna Installation Considerations

The EX500 can operate with two different datalink systems simultaneously. Avidyne’s two-way Narrowcast datalink system utilizes a built-in ORBCOMM transceiver to provide weather data tailored for the aircraft’s current flight plan. The EX500 also supports the XMD076 XM WX Receiver from Heads Up Technologies, which is a Broadcast datalink system providing larger amounts of weather data. With both Narrowcast and Broadcast datalink systems installed, the EX500 will provide Avidyne’s unique Multilink features, which include text messaging, flight tracking, and enhanced weather coverage.

The Narrowcast datalink system is designed to work with a VHF antenna covering the band from 137 MHz to 151Mhz. If an existing comm antenna is in the preferred location for a datalink antenna, consider using the Avidyne DC50 Datalink Coupler and replacing the existing comm antenna with a combined VHF/datalink antenna. Please contact Avidyne for details.

The Broadcast datalink system operates in the S-band at 2.3 GHz. Several types of combination antennas are available in addition to the standalone XM antenna. Contact Heads Up Technologies or Comant, Inc. for details on the available antennas.

#### 2.3.1. Narrowcast Antenna Details

To improve Narrowcast reception performance and minimize potential damage to the EX500 Narrowcast datalink transceiver, an antenna design with a DC-short between the antenna center conductor and shield termination is required. The following commercially available antennas satisfy the above requirement:

<i>Manufacturer</i>	<i>P/N</i>	<i>Application</i>
Comant	CI 177-4	Max 210 kts indicated at 10,000 ft
	CI 248-30	Max 210 kts indicated at 10,000 ft
	CI 108-1	Max 600 kts TAS at 35,000 ft
	CI 211-1	Max 600 kts TAS at 35,000 ft

Sensor Systems	S65-8280-10	Max 600 kts TAS
Refer to manufacturers for detailed performance specifications and aircraft applicability		

Due to the low signal levels inherent with satellite communications, the following guidelines and recommended practices should be adhered to :

- Mount the Narrowcast antenna on the aircraft top-side, as high on the fuselage as practical.
- Mount the antenna no closer than 36 inches to other transmitters. Relocation of other less location-sensitive transmitters may be necessary to achieve optimal datalink performance.
- On radar-equipped aircraft mount the antenna as far aft as possible, but no closer than 36 inches from vertical obstructions (ex. vertical stabilizer). Reflected radar energy may cause damage to the datalink transceiver.
- Install in accordance with the applicable portions of AC43.13 and antenna manufacturer instructions.

Additional installation guidance is found in Appendix E of this installation manual.

**NOTE:**

This installation manual does not contain approved data for type specific aircraft antenna installations.

### 2.3.2. Broadcast Antenna Details

- Mount the antenna no closer than 36 inches to VHF-Comm transmitters of 15 Watts or less. For more powerful transmitting antennas, separation should be a minimum of 48 inches.

If an XM/VHF-Comm combo antenna is being installed and is replacing the operation of an existing approved antenna installation, the existing separations are acceptable.

- SATCOM antennas transmit at 40 Watts and should be separated by the largest distance possible. This distance must be a minimum of 36 inches.
- When routing the XM antenna cable, the maximum possible separation from transmitter antenna feed cables must be considered, especially with SATCOM and other high power transmitters. Antenna feed cables of VHF transmitters of 15 Watts or less should require only a minimal separation.
- Receive-only antennas such as GPS and ADF do not produce interference and require little separation. The XM antenna should be placed as close as possible to these types of antennas to gain separation from transmitters.
- For further details, including installation pre-testing, please refer to the Heads Up Technologies *XMD076 XM WX Receiver Installation Manual*, document number XMD076-3.

### 2.3.3. Weight and Balance

A Weight and Balance calculation aircraft is required as part of installation approval process. Follow the guidelines as established in AC 43.13-1B, Chapter 10, Section 2. The unit and installation kit materials weight supplied below may be used.

<i>Description</i>	<i>Weight</i>
EX500 Multi-Function Display with tray and connectors	7.2 lb (3.3kg)

### 3. Post Installation Configuration Guide

This section is intended as a guideline to post installation set up and configuration. For a complete and detailed description of the unit functionality, refer to the latest revision of the Pilot Operating Handbook, P/N 600-00078-000.

#### 3.1. System Configuration

The following activities are to be completed during the EX500 configuration process:

- Verify installed sensor option support
- Verify installed software version number
- Setup sensor port interfaces and associated operational options
- Adjust the Bezel key backlighting level to match dimming range of other installed avionics
- Confirm EX500 setup configuration.

##### 3.1.1. Entering The Maintenance Mode

To configure the EX500 to the specific interface configuration of the installation, EX500 MAINTNANCE MODE must be accessed as follows (with the aircraft avionics master ON and circuit breaker IN):

- Press the **PWR** button to turn on the Display.
  - Allow the MFD to run through the initialization process. (approximately 1 minute)
  - You will be prompted to press any bezel key to continue.
- Press any key to gain access to the normal operating mode.
  - The *Page Indicator* will have the Map box highlighted.
- Rotate the **Page** knob to highlight “Aux”.
- Simultaneously depress **L1** (top left) and **L3** (middle left) function keys. Hold them for approximately 5 seconds until the Page indicator is removed from view.

The “Maintenance Mode” page should now be in view. Holding the **L1** and **L3** keys too long will cause the unit to transfer into a Maintenance Mode sub-page. Press **Cancel** to return to the Maintenance Mode Main page.

Once in the maintenance mode, follow the appropriate set up and configuration sheets of this guide.



Figure 2: Maintenance Mode Main Page (actual view depends on installed options)

### 3.2. EX500 Sensor Interface Setup

The EX500 receives and transmits data via user configurable interface ports. To support the many sensor types that are encountered in the typical aircraft installation, the installer must configure the EX500 once the unit is installed. Port assignments may be made or modified for each sensor type (GPS/FMS, Traffic, etc.) through the EX500 Maintenance Mode. The configuration activity includes:

- Confirmation that the EX500 is provisioned for the sensor set installed on the aircraft,
- Assignment of the interface port for each sensor, as wired by the installer,
- Configuration of each sensor port for proper operation,
- Selection of sensor specific operation settings\*

\* Selection of sensor operation settings should be performed under the guidance of the manufacturer's instructions for the specific sensor installed. The EX500 port configuration may be viewed from the **System Info** utility.

The following section details setup procedures for these sensor interfaces.

#### 3.2.1. EX500 Sensor Interface Provisioning Confirmation

Figure 1 depicts the Maintenance Mode main page. The left-hand column of buttons is dedicated to initiating setup utilities for the sensor set that the EX500 is configured to support. The button legends correspond to sensors supported by the EX500. Figure 3 depicts a unit, which supports GPS/FMS, traffic and lightning sensors.

- Verify that the sensor setup options conform to the sensors used in the installation.



Figure 3: Maintenance Mode Sensor Support

#### 3.2.2. Configuration Options

To support the many sensor types encountered in the typical aircraft installation, the installer must configure the EX500 for the sensor type and select the correct port configuration. Table 1 lists sensor options and their associated port configurations. This data may be used when executing Maintenance

Mode sensor setup utilities. Port selection must match the aircraft wiring. Default port assignments must match the wiring instructions given in Appendices E through Q. Refer to Appendix F for configurations with dual GPS/FMS inputs.

When the MFD is being used in conjunction with a digital radar system, ARINC 429 port 3 and ARINC 453 port 1 are default settings, which are not selectable via the procedures contained in this document. Figure 7 provides a cross reference between port assignments and functional use.

**Table 1: Sensor Port Configuration Options**

Sensor Type	Sensor Option	Port Type	Default Port	System Type	Port Configuration
GPS/FMS	GAMA 429 Format	ARINC 429	1	Garmin GPS 155XL, GNC 300XL Garmin GPS 400/500 Garmin GNC 420 Garmin GNS 430/530 (GAMA 429 Graphics w/INT) Bendix/King KLN-90B Universal UNS-1B	Speed: Low Speed: Low Speed: Low Speed: Low Speed: High Speed: High
	King/Aviation Format	RS-232	1	Honeywell GNS-XLS Garmin GNS 430/530 Bendix/King KLN-90B	Baud: 9600 Baud: 9600 Baud: 9600
	Northstar Format NMEA 0183 Format	RS-232 RS-232	1 1	Trimble 2000, 2101 UPSAT – all GPS units Northstar M3 Garmin 150/250	Baud: 9600 Baud: 9600 Baud: 4800
Traffic	Not Installed				
	TCAD	RS-232	2	Ryan 9900B, 9900BX	N/A
	TAS	ARINC 429	2	L3 Skywatch, Skywatch HP	N/A
	TAS	ARINC 429	2	Honeywell KTA-870, KMH-880	N/A
	TIS-G	ARINC 429	2	Garmin GTX330	N/A
	TCAS	ARINC 429	2	Goodrich TCAS 791	N/A
TCAS	ARINC 429	2	Honeywell CAS-66A, KTA-970	N/A	
Broadcast Datalink	Not Installed XM Radio	RS-232	4	Heads Up Technologies XMD076	N/A
Lightning	Not Installed WX-500	RS-232	3	WX500	N/A
RADAR	The digital radar port is factory configured and requires no setup.				
TAWS	Not Installed Honeywell EGPWS	ARINC 429/ ARINC 453	4 2	Honeywell EGPWS	N/A
Map Heading	Synchro	N/A	N/A	N/A	N/A

Sensor Type	Sensor Option	Port Type	Default Port	System Type	Port Configuration
{Source}	FMS/GPS Traffic Stormscope None (use GPS Track)				

Figure 4 Main Connector (P2) Pin Assignments

Pin	Function	Default	Pin	Function	Default
1	TTL1 (R/T ON)		40	28 VDC	
2	RESERVED		41	28 VDC	
3	RESERVED		42	28 VDC	
4	GND		43	ARINC 429 TX1 A	
5	ARINC 429 RX1 A	GPS A	44	RESERVED	
6	ARINC 429 TX2 A		45	ARINC 429 RX2 A	TRAFFIC
7	TTL2 (TAS)		46	ARINC 429 TX3 A	RADAR
8	ARINC 429 RX3 A		47	TTL3 (TAS)	
9	ARINC 429 TX4 A	TAWS	48	ARINC 429 RX4 A	
10	RS232 TX1		49	RS232 TX3	WX500
11	RS232 RX1	GPS A	50	RS232 RX3	WX500
12	RS232 RTN1	GPS A	51	RS232 RTN3	WX500
13	RESERVED		52	RESERVED	
14	RESERVED		53	RESERVED	
15	GND		54	SYNCHRO Z IN	
16	SYNCHRO X IN		55	ARINC 453 TX3 A	(UNUSED)
17	SYNCHRO REF LO		56	ARINC 453 RX2 A	TAWS
18	DIMMING		57	GND	
19	RESERVED		58	ARINC 453 TX3 B	(UNUSED)
20	GND		59	ARINC 453 RX2 B	TAWS
21	RESERVED		60	PWR GND	
22	RESERVED		61	PWR GND	
23	RESERVED		62	PWR GND	
24	RESERVED		63	ARINC 429 TX1 B	

Pin	Function	Default	Pin	Function	Default
25	ARINC 429 RX1 B	GPS A	64	RESERVED	
26	ARINC 429 TX2 B		65	ARINC 429 RX2 B	TRAFFIC
27	RESERVED		66	ARINC 429 TX3 B	RADAR
28	ARINC 429 RX3 B		67	RESERVED	
29	ARINC 429 TX4 B	TAWS	68	ARINC 429 RX4 B	
30	RS232 TX2	TCAD	69	RS232 TX4	XM, GPS B
31	RS232 RX2	TCAD	70	RS232 RX4	XM, GPS B
32	RS232 RTN2	TCAD	71	RS232 RTN4	XM, GPS B
33	SYNCHRO VALID		72	RESERVED	
34	RESERVED		73	RESERVED	
35	SYNCHRO Y IN		74	SYNCHRO REF HI	
36	GND		75	ARINC 453 RX1 A	RADAR
37	GND		76	RESERVED	
38	RESERVED		77	RESERVED	
39	RESERVED		78	ARINC 453 RX1 B	RADAR

Figure 5 ARINC Port Pinout Cross-Reference

ARINC 429 Ports			ARINC 453 Ports		
Port	Signal	Pin	Port	Signal	Pin
1	TX A	43	1	TX A	N/A
	TX B	63		TX B	N/A
	RX A	5		RX A	75
	RX B	25		RX B	78
2	TX A	6	2	TX A	N/A
	TX B	26		TX B	N/A
	RX A	45		RX A	56
	RX B	65		RX B	59
3	TX A	46	3	TX A	55
	TX B	66		TX B	58
	RX A	8			
	RX B	28			



<b>ARINC 429 Ports</b>			<b>ARINC 453 Ports</b>		
4	TX A	9			
	TX B	29			
	RX A	48			
	RX B	68			

**Figure 6 RS-232 Port Pinout Cross-Reference**

<b>RS-232 Ports</b>		
Port	Signal	Pin
1	TX	10
	RX	11
	RTN	12
2	TX	30
	RX	31
	RTN	32
3	TX	49
	RX	50
	RTN	51
4	TX	69
	RX	70
	RTN	71

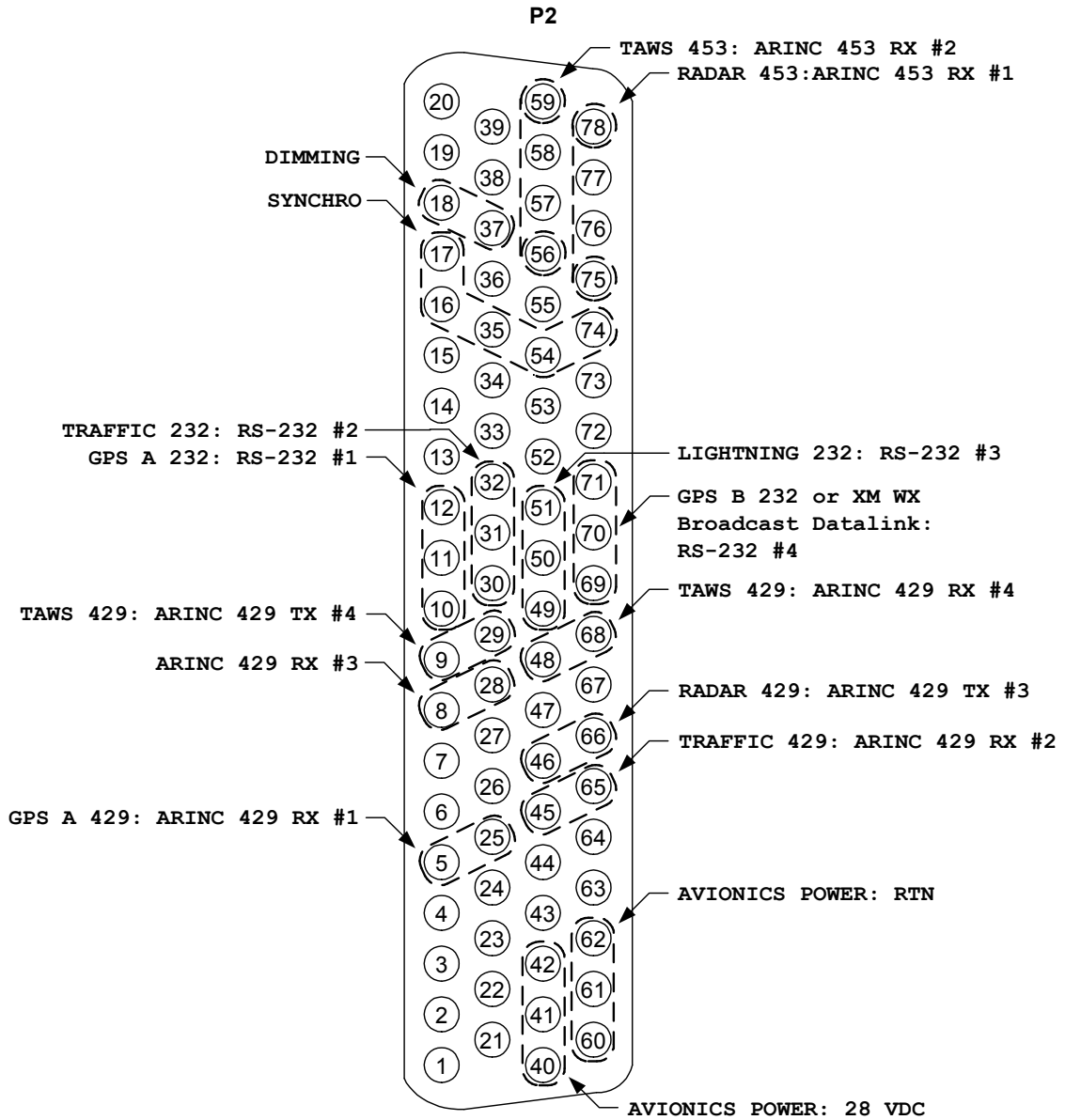

P2 - MAIN CONNECTOR  
SERIAL DATA PORT  
ASSIGNMENTS

NOTES:

1. AVAILABLE FOR GPS B WHEN TRAFFIC 429: ARINC 429 RX #2  
PORT IS NOT WIRED
2. AVAILABLE FOR GPS B WHEN TAWS 429: ARINC 429 TX #4  
PORT IS NOT WIRED

Figure 7: Main Connector Port Assignments

### 3.2.3. Configuration Selection

To configure a specific sensor type, enter the appropriate setup utility by depressing the corresponding bezel key. Figure 8 depicts the setup page for the GPS/FMS interface. Four operations are supported for each sensor setup page.

- **Select:** Change the highlighted parameter box. {knob rotation}
- **Change:** Modify the parameter in the highlighted box. {knob rotation}
- **Save:** Store any setup changes made since entering the page and return to the Maintenance Mode Main page. {button press}
- **Cancel:** Ignore any setup changes made since entering the page and return to the Maintenance Mode Main page. {button press}



Figure 8: GPS/FMS System Setup Page

### 3.3. GPS/FMS System Setup

Based upon tray wiring, Table 1 data, and sensor manufacturer’s instructions, configure the GPS/FMS receiver input formats, port selections and port speeds for GPS/FMS avionics interfaced to the EX500. Refer to Appendix G for Receiver B (GPS B) configuration guidance.

**Note:** Garmin GNS4xx and GNS5xx receivers must be configured for “GAMA 429 Graphics w/INT” if interfaced via ARINC 429. Refer to Garmin installation manuals for details on changing this setting.

When complete, press **Save** to confirm changes made or press **Cancel** to retain previous system settings and return to Maintenance Mode main page.

### 3.4. Traffic System Setup

Based upon tray wiring, Table 1 data, and sensor manufacturer’s instructions, configure the traffic sensor input formats, and port selections for traffic sensor interfaced to the EX500.

System configuration options include (option availability depends on EX500 configuration ordered):

System	Option	Values	Notes	
TCAD	Shields	Terminal Standard Enroute		
	Range	Terminal	0.5 – 1.5 nm	
		Standard	1 – 3 nm	
		Enroute	2 – 15 nm	Limited to 6 nm max. by the 9900B sensor
	Height	Terminal	200 – 1000 ft	
		Standard	500 – 1500 ft	
Enroute		1000 – 2000 ft		
TAS	External Controller	Check/No Check	Check this box if a dedicated external Skywatch controller is installed. With this box checked the EX500 will not initiate Skywatch standby or Self Test functions.	
TCAS	Maximum Intruders	Display All (31) Specified by Sensor Minimum (8)	Selects the maximum number of intruders that can be simultaneously displayed on the EX500.	
	Sensor Range	0 – 128 nm	Sets the range limit of intruders displayed on the EX500. This limit is independent of limits set on the TCAS system.	
	External Mode Control (ABV/BLW/NRM)	Check/No Check	When checked, the EX500 will not control the TCAS altitude mode.	
	External Range Control	Check/No Check	When checked, the EX500 will not control the TCAS range setting.	

When complete, press **Save** to confirm changes made or press **Cancel** to retain previous system settings and return to Maintenance Mode main page.



Figure 9: Traffic System Setup Page

### 3.5. Lightning System Setup

Based upon tray wiring, Table 1 data, and sensor manufacturer’s instructions, configure the lightning sensor input formats and port selections for the lightning sensor interfaced to the EX500. Refer to the WX-500 manual for further lightning system operational details.

System configuration options include:

<b>System</b>	<b>Option</b>	<b>Values</b>	<b>Notes</b>
WX-500	Operating Mode	Weather	Normal operating mode
		Noise Monitor	Supports noise mapping tests (May require second button press to advance from “Noise Monitor” to “Display Off”)
		Demo	Used to learn lightning operations
	Stab Type	Synchro to WX-500	The WX-500 will use the synchro supplied heading data connected directly to the WX500.
		Stepper to WX-500	The WX-500 will use stepper data from a remote compass system.
		Use Map Heading/Track	The WX-500 will use orientation information supplied by the EX500 based upon the “Map Heading Configuration”
	Enable Lightning Ahead Warning?	Check/No Check	When checked, the EX500 will issue lightning ahead warning messages.
	Antenna on Top?	Check/No Check	To be checked if the lightning sensor antenna is located on top of the aircraft and must correspond with the WX-500 jumper settings.

Press **Save** to confirm changes made or press **Cancel** to retain previous system settings.

The EX500 is also able to report system data reported from the WX-500 via the **WX500 Diags** key and initiate the WX-500 self-test function by activation of the **WX500 Self Test** key. These two functions are only available when the WX-500 sensor is powered up and communicating with the EX500. Refer to the WX-500 manual for details on reported system data and self-test operation.



Figure 10: Lightning System Setup Page

### 3.6. RADAR System Setup

Table 2 lists the RADAR-types supported by the EX500-Series MFD. From the Radar Setup page, select installed radar type, **SAVE** the selection and **RESTART** the system.

Table 2: EX500-Series Radar Support

EX500	Sensor	EX500	Sensor
700-00007-001	Not Installed	700-00007-005	Bendix/King RS-181A
			Bendix/King RS-181A-VP
700-00007-002	Bendix RT-131A/DA-1203A		Bendix/King RS-811A
	Bendix RT-1201A/DA-1203A		Bendix/King RS-841A
			Bendix/King RS-841A-VP
700-00007-003	Bendix RT-1301A/B /DA-1203A		Bendix/King RS-861A
			Bendix/King RS-861A-VP
700-00007-004	Bendix RT-131A/AT-133A		AlliedSignal ART-2000
	Bendix RT-131A/AT-133A (INV)		AlliedSignal ART-2100
	Bendix RT-131A/DA-144A		
	Bendix RT-131A/DA-144A (INV)		
	Bendix ART-161A		
		700-00007-006	Collins WXT-250A
			Collins WXT-250B/200mi
			Collins WXT-250B/250mi

Configuration options are radar specific, presented as available per radar-type, and may be selected from the Radar Setup page after the system restarts.

Table 3 describes option choices. Refer to the Radar installation and operations manuals for further details.

Option	Value	Notes
Park Position	Last position	Set the park/startup position for the radar antenna tilt angle.
	Full up	
	Centered	
	Full down	
Beam Width	0.0° – 19.5°	Defines the Width and Height of the radar sweep graphical depiction on the EX500 radar display. Typical beam widths are provided below.
Beam Height	0.0° – 19.5°	
Enable Gain Control	Check/No Check	Enables R/T variable gain control to be commanded from the EX500.
Enable VP	Check/No Check	When checked, enables Radar Vertical Profile mode.
Enable Auto-Tilt Control	Check/No Check	When checked, enables Radar auto-tilt mode.
Primary Indicator (1)	Check/No Check	When checked, enables EX500 control of radar functions.
Disable Stabilization	Check/No Check	Disables EX500 display of the “Stab Off” annunciation
Enable Automatic Standby	Check/No Check	When checked, enables the EX500 to auto-command the radar to standby when ground is sensed to be below 20 kts.

Table 3: Radar Configuration Options

Antenna Width	Generic Beam Width	Bendix/King Radars	Collins Radar
10"	10°	10°	9.5°
12"	8°	8°	8°
18"	5°	5.6°	6°

Table 4: Radar Feature Matrix

	Range Values	Scan Arcs supported	# of colors	Multiple Ind	Stabilization	Stab on-off control	Auto-Tilt	VP	Roll Trim adj	ARL/PAC	Target Alert	Tilt settings	Azimuth Lines other than 0°
Bendix/King													
RT-131A (RDR-150) [RT-131A/AT-133A] [RT-131A/AT-133A (INV)] [RT-131A/DA-144A] [RT-131A/DA-144A (INV)]	5, 10, 20, 40, 80, 160	90°	3				▽					±15°	
RT-131A (RDR-1100) [RT-131A/DA1203A]	10, 20, 40, 80, 160, 240	60°, 120°	3		•	•	▽		•			±15°	



	Range Values	Scan Arcs supported	# of colors	Multiple Ind	Stabilization	Stab on-off control	Auto-Tilt	VP	Roll Trim adj	ARL/PAC	Target Alert	Tilt settings	Azimuth Lines other than 0°
ART-161A (RDR-160) [ART-161A]	5, 10, 20, 40, 80, 160	90°	3				▽					±15°	
RS-811A (RDS-81) [RS-811A]	10, 20, 40, 80, 160, 240	90°	4	•	•	•	▽		•			±15°	
RS-181A (RDS-82) [RS-181A]	10, 20, 40, 80, 160, 240	90°	4	•	•	•	▽		•			±15°	
RS-181A-VP (RDS-82VP) [RS-181A-VP]	10, 20, 40, 80, 160, 240	90°	4	•	•	•	▽	•	•			±15°	
RS-841A (RDS-84) [RS-841A]	5, 10, 20, 40, 80, 160, 240, 320	120°	4	•	•		▽		•			±15°	
RS-841A-VP (RDS-84VP) [RS-841A-VP]	5, 10, 20, 40, 80, 160, 240, 320	120°	4	•	•		▽	•	•			±15°	
RS-861A (RDS-86) [RS-861A]	5, 10, 20, 40, 80, 160, 240, 320	120°	5	•	•		•		•	•		±15°	
RS-861A-VP (RDS-86VP) [RS-861A-VP]	5, 10, 20, 40, 80, 160, 240, 320	120°	5	•	•		•	•	•	•		±15°	
ART-2000 (RDR-2000) [ART-2000]	10, 20, 40, 80, 160, 240	90°, 100°	4	•	•	•	▽	•	•		•	±15°	
ART-2100 (RDR-2100) [ART-2100]	5, 10, 20, 40, 80, 160, 240, 320	60°, 90°, 100°, 120°	5	•	•	•	•	•	•	•	•	±15°	
RT-1201A (RDR-1100/1200) [RT-1201A/DA1203A]	10, 20, 40, 80, 160, 240	60°, 120°	3		•	•	▽		•			±15°	
RT-1301A/B (RDR-1300) [RT-1301A/B /DA1203A]	10, 20, 40, 80, 160, 240	60°, 120°	3		•	•	▽		•			±15°	±15°, ±30°
Collins													

	Range Values	Scan Arcs supported	# of colors	Multiple Ind	Stabilization	Stab on-off control	Auto-Tilt	VP	Roll Trim adj	ARL/PAC	Target Alert	Tilt settings	Azimuth Lines other than 0°
WXT-250A (WXR-270) [WXT-250A]	10, 25, 50, 100, 250	120°	3		•	•	▽				•	±15°	±30°
WXT-250B (WXR-270A) [WXT-250B/200MI]	10, 25, 50, 100, 200	120°	4		•	•	▽			•	•	±15°	±30°
WXT-250B (WXR-270) [WXT-250B/250MI]	10, 25, 50, 100, 250	120°	4		•	•	▽			•	•	±15°	±30°

- Support native to R/T
- ▽ Support provided by Avidyne software

NOTE: Features provided by software for ALL sensors:

- Beam Altitude display
- Beam Width display
- Bearing Line
- Hold (Freeze)
- Startup/Standby Tilt Parking

### 3.6.1. RADAR System Calibration

Calibration of the Radar R/T unit requires access to the radar calibration page on the FlightMax EX500 unit. This section explains how to access the calibration page and complete the radar calibration. Calibration of the radar R/T should be performed according to the procedures and specifications for the specific unit installed in the aircraft.

Calibration can be performed after the Radar has been installed, setup and checked out per the radar manufacturer's instructions.

#### 3.6.1.1. Calibration with Bendix/King RDS-8X Series Radars

**NOTE:**

In order to avoid recalibration of the R/T when upgrading from an **ALREADY CALIBRATED BENDIX/KING INDICATOR**, it is suggested that the installer activate the Maintenance Page of the original Bendix/King indicator **BEFORE IT IS REMOVED** and write down the value for 'Roll Trim'. This value may be entered in the EX500 to maintain the existing calibration.

To calibrate the system:

- Enter the FlightMax EX500 Maintenance Mode per Section 3.1.1
- Access the **Calibration** Mode
- Perform the calibration according to the specifications in the R/T unit's manual.
- Press Enter to accept new values.

### 3.6.1.2. Calibration with AlliedSignal (Bendix/King) 2XXX Series Radars

This section describes Post-Installation System Configuration and Calibration of the Bendix/King RDR-2000 and RDR-2100 Radar Systems using the FlightMax EX500 and replaces specific sections of the Bendix/King Installation Manual that describe configuration and calibration using the Bendix/King IN-182A Indicator.

To configure and calibrate the system, follow the original B/K Installation Manual substituting the following two sections with the instructions provided herein.

#### 2.4.1 CONFIGURATION PROCEDURE USING RADAR INDICATOR

##### 2.4.4.1 STABILIZATION CALIBRATION WITH RADAR INDICATOR.

**NOTE:**

If the EX500 is replacing the indicator of currently installed and previously calibrated RDR 2000 series radar, this procedure may not be necessary. The calibration values are contained in the configuration module of the R/T and should remain valid. Avidyne does recommend that the installer check the calibration values after the Avidyne unit has been installed to ensure that nothing has changed.

#### 2.4.1 CONFIGURATION PROCEDURE USING A PERSONAL COMPUTER

The R/T Configuration Module must be configured using the Allied Signal KPA 900 Configuration Module Programmer Kit (Part Number 050-03311-0000) in conjunction with a personal computer. Refer to the configuration module user data for detailed setup instructions. Follow the instructions for the programmer.

##### 2.4.1.1 Antenna Clearance Check

Complete the Antenna Clearance Check by performing the following steps:

- A. Set the radar Function to SBY.
- B. Set the radar Mode to GND.
- C. Reduce the gain until the gain indicator shows the minimum setting.
- D. Set the Antenna Tilt to full UP (U 15.0).
- E. Set Range to 240 NM.
- F. Set Function to TEST.
- G. Set the radar mode to GND
- H. Reduce the gain until the gain indicator in the upper left shows the minimum setting.
- I. Set the Antenna Tilt to Full UP (U 15.0)
- J. Set the Range to 240 NM
- K. Navigate to the SETUP page and enter the Maintenance Mode.
- L. Press the Radar Setup button.
- M. Press the Calibration button to display the RT CALIBRATION DATA page. Upon display of the RT CALIBRATION DATA page with the system in calibration mode, all fault fields will flash briefly. This verifies calibration mode is entered.
- N. Adjust the gain to obtain a value of -26.5 to -28 in the GAIN POT /2 field. This will initiate the antenna clearance scan. The antenna will move to each of the extreme positions to determine that there is no interference with antenna movement and all scan motors are working properly.

#### 2.4.4.1 STABILIZATION CALIBRATION WITH FLIGHTMAX EX500

- A. Set the radar Function to SBY.
- B. Set the radar Mode to GND.
- C. Reduce the gain until the gain indicator in the upper right shows the minimum setting.
- D. Set the Antenna Tilt to full UP (U 15.0).
- E. Set Range to 240 NM.  
 Note: Failure to perform steps A to E will prevent the ART from entering calibration mode. If more than one radar indicator is installed in the system, all but one indicator must be in the OFF or SBY position in order for the system to enter the calibration mode.
- F. Enter the Maintenance Mode
- G. Press the Radar Setup button
- H. Press the Calibration button to display the RT CALIBRATION DATA page. See figure 2-5 in the Bendix/King Installation Manual. Upon display of the RT CALIBRATION DATA page with the system in calibration mode, all fault fields will flash briefly. Adjust Roll Trim with the outer knob to 0°.
- I. If desired, copy all displayed values to a note pad in case there is a need to recall a value that is accidentally changed.
- J. 400 Hz REF GAIN  
 If an ARINC 429 gyro is being used, proceed to Step N.
  1. Set the tilt table to 0 Deg. pitch and roll.
  2. Use the GAIN controls to set the GAIN POT /2 setting between -28 and -30.
  3. Adjust the TILT SETTING with the inner knob between 5 and 10 UP to increment the 400 HZ REF field to 0.0 ±1.0 Deg. (adjusting the TILT SETTING between 5 and 10 DOWN will decrement the numbers). Upon reaching the desired setting, quickly adjust the TILT SETTING to above 10 to lock in the setting. See figure 2-11 in the Bendix/King Installation Manual.
  4. Proceed to step K  
 Note: If the 400 Hz REF field is zero (0), and will not change when the TILT knob is adjusted, check that the correct gyro has been selected when programming the Configuration Module.
- K. PITCH GAIN
  1. Set the tilt table for 10 Deg. pitch up.
  2. Adjust the GAIN buttons for a GAIN POT setting between -24.5 and -26.5.
  3. Adjust the TILT SETTING between 5 and 10 UP to increment the PITCH ANGLE field to 10.0 ±1.0 Deg. (adjusting the TILT SETTING between 5 and 10 DOWN will decrement the numbers). Upon reaching the desired setting, quickly adjust the TILT SETTING to above 10 to lock in the setting. See figure 2-11 in the Bendix/King Installation Manual.
  4. Set for 10 Deg. PITCH DOWN. Repeat steps 2 and 3.
  5. Set the tilt table to 0 Deg. pitch and roll.
  6. Proceed to step M.

- L. PITCH OFFSET
  1. Adjust the GAIN controls for a GAIN POT setting between -17.5 and -19.5.
  2. Check that the tilt table is set for 0 Deg. pitch.
  3. Adjust the TILT SETTING between 5 and 10 UP to increment the PITCH ANGLE field to 0.0 ±1.0 Deg. (adjusting the TILT SETTING between 5 and 10 DOWN will decrement the numbers). Upon reaching 0 Deg. ±1.0°, quickly adjust the TILT SETTING to above 10 to lock in the setting. See figure 2-11 in the Bendix/King Installation Manual.
  4. Set the tilt table to 10 Deg. pitch up. The value should be 10.0U ±1.0°. If the value is out of range, repeat

- Step L.
- 5. Set the tilt table to 10 Deg. pitch down. The value should be 10.0D  $\pm$ 1.0°. If the value is out of range, repeat Step L.
- 6. Set the tilt table to 0 Deg. pitch. The value should be 0.0  $\pm$ 1.0°. If the value is out of range, repeat Step M.
- 7. Proceed to Step N.
- M. AHRS ARINC 429 PITCH OFFSET
  - 1. Adjust the GAIN buttons for a GAIN POT setting between -10.5 and -12.5.
  - 2. Check that the tilt table is set for 0 Deg. pitch.
  - 3. Adjust the TILT SETTING between 5 and 10 UP to increment the PITCH ANGLE field to 0.0  $\pm$ 1.0 Deg (adjusting the TILT SETTING between 5 and 10 DOWN will decrement the numbers). Upon reaching 0 Deg.  $\pm$ 1.0°, quickly adjust the TILT SETTING to above 10 to lock in the setting. See figure 2-11 in the Bendix/King Installation Manual.
  - 4. Set the tilt table to 10 Deg. pitch up. The value should be 10.0U  $\pm$ 1.0°. If the value is out of range, repeat Steps 1, 2 and 3 of this section.
  - 5. Set the tilt table to 10 Deg. pitch down. The value should be 10.0D  $\pm$ 1.0°. If the value is out of range, repeat Steps 1, 2, 3 and 4 of this section.
  - 6. Set the tilt table to 0 Deg. pitch. The value should be 0.0  $\pm$ 1.0°.
  - 7. Proceed to Step P.
- N. ROLL GAIN
  - 1. Set the tilt table for 10 Deg. roll right.
  - 2. Adjust the GAIN buttons for a GAIN POT setting between -21.0 and -23.0.
  - 3. Adjust the TILT SETTING between 5 and 10 UP to increment the ROLL ANGLE field to 10.0  $\pm$ 1.0 Deg. (adjusting the TILT SETTING between 5 and 10 DOWN will decrement the numbers). Upon reaching the desired setting, quickly adjust the TILT SETTING to above 10 to lock in the setting. See figure 2-11 in the Bendix/King Installation Manual.
  - 4. Set the tilt table for 10 Deg. roll left. Repeat Steps 2 and 3 of this section.
  - 5. Set the tilt table for 0 Deg. pitch and roll.
  - 6. Proceed to Step O.
- O. ROLL OFFSET
  - 1. Adjust the GAIN buttons for a GAIN POT setting between -14.0 and -16.0.
  - 2. Check that the tilt table is set for 0 Deg. roll.
  - 3. Adjust the TILT SETTING between 5 and 10 UP to increment the ROLL ANGLE field to 0.0  $\pm$ 1.0 Deg. (adjusting the TILT SETTING between 5 and 10 DOWN will decrement the numbers). Upon reaching 0 Deg.  $\pm$ 1.0°, quickly adjust the TILT SETTING to above 10 to lock in the setting. See figure 2-11 in the Bendix/King Installation Manual.
  - 4. Set the tilt table to 10 Deg. roll right. The value should be 10.0R  $\pm$ 1.0°. If the value is out of range, repeat Step N.
  - 5. Set the tilt table to 10 Deg. roll left. The value should be 10.0L  $\pm$ 1.0°. If the value is out of range, repeat Step N.
  - 6. Set the tilt table to 0 Deg. roll. The value should be 0.0  $\pm$ 1.0°. If the value is out of range, repeat Step O.
  - 7. Proceed to Step P.

P. AHRS ARINC 429 ROLL OFFSET

1. Adjust the GAIN controls for a GAIN POT setting between  $-7.0$  and  $-9.0$ .
2. Check that the tilt table is set for 0 Deg. roll.
3. Adjust the TILT SETTING between 5 and 10 UP to increment the ROLL ANGLE field to  $0.0 \pm 1.0$  Deg. (adjusting the TILT SETTING between 5 and 10 DOWN will decrement the numbers). Upon reaching 0 Deg.  $\pm 1.0^\circ$ , quickly adjust the TILT SETTING to above 10 to lock in the setting. See figure 2-11 in the Bendix/King Installation Manual.
4. Set the tilt table to 10 Deg. roll right. The value should be  $10.0R \pm 1.0^\circ$ . If the value is out of range, repeat Step P.
5. Set the tilt table to 10 Deg. roll left. The value should be  $10.0L \pm 1.0^\circ$ . If the value is out of range, repeat Step P.
6. Set the tilt table to 0 Deg. roll. The value should be  $0.0 \pm 1.0^\circ$ .
7. Proceed to Step Q.

Q. SAVE CONFIGURATION

1. Adjust the GAIN controls for a GAIN POT setting between  $-3.5$  and  $-5.5$ .
2. Set the TILT SETTING to 15.0D. The fault fields will flash indicating the save procedure is beginning. If the save procedure is successful, the GYRO fault will disappear and the azimuth count will step.
3. If the GYRO fault remains, set TILT to 0 and repeat step 2 of this section.

### 3.6.2. Roll Trim Adjustment

For procedures that require the Roll Trim to be adjusted, the installer can access the Roll Trim selection from the Maintenance Mode **Radar Setup** utility. When selected, the Roll Trim value appears on the Radar screen and may be modified by the Roll Trim control knob. When all settings of the Roll Trim have been accomplished, save the new setting by returning to the Radar Setup using the **Back** button.

### 3.7. TAWS System Setup

Based upon tray wiring, Table 1 data, and sensor manufacturer's instructions, configure the TAWS sensor input formats and port selections for the TAWS sensor interfaced to the EX500 (option availability depends on EX500 configuration ordered).

No additional system configuration options are required with the EX500 supported TAWS sensors.

Press **Save** to confirm changes made or press **Cancel** to retain previous system settings.

### 3.8. Narrowcast Datalink Setup

The EX500 is pre-configured for Narrowcast datalink operation. Avidyne recommends installing a Narrowcast antenna even if Broadcast datalink is being installed, to provide the user with all the features of the unique Multilink system.

If a Narrowcast datalink antenna is *not* being installed, select the **Aircraft Setup** page from Maintenance Mode and set the Narrowcast selection to "Not Installed". If this step is omitted, the user will see a steady stream of Narrowcast error messages as the EX500 attempts to establish the Narrowcast connection.

Accessing the Datalink Info page from the System Info utility, which is entered from the Maintenance Mode menu, gives details of the configuration.

Figure 11 depicts the **Datalink Info** table. Verify the presence of SC Serial Number and version information on this screen.

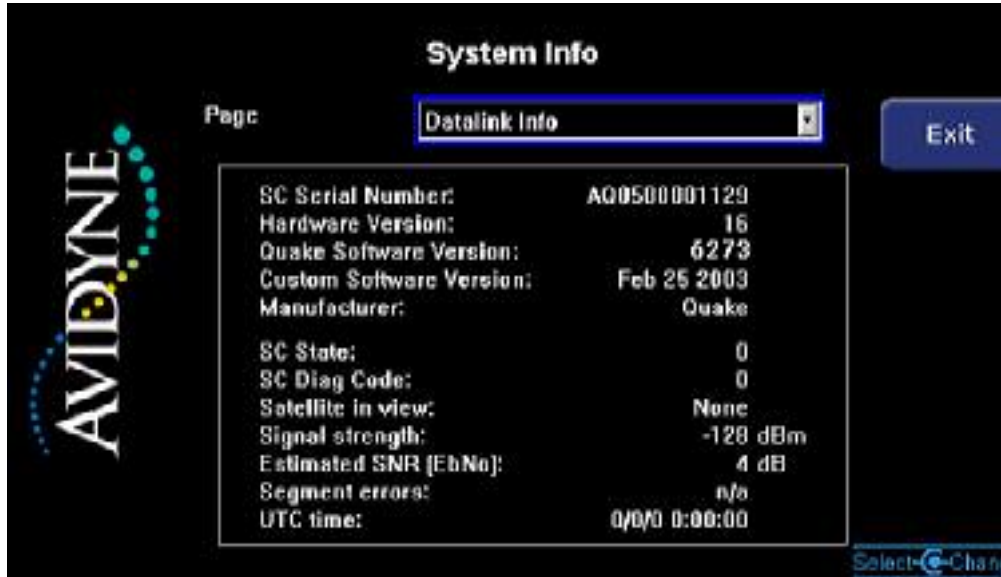

Figure 11: Datalink Info Table

### 3.9. Broadcast Datalink Setup

The MFD supports the Heads Up XMD076 XM data receiver.

Confirm that the datalink setup fields on the Aircraft Setup page are configured for:

**Broadcast**– Select “XM Radio”. This will enable the datalink functionality and communication with the satellite data receiver.

**Port** – Should be set to the serial port used for the satellite receiver, nominally RS232 4. Save settings and restart MFD.

### 3.10. Map Heading Source Setup

Based upon tray wiring, Table 1 data, and sensor manufacturer’s instructions, configure the EX500 for the intended heading sensor input. Refer to section 2.2.2.2 of this manual.

System configuration options include:

System	Source	Values	Notes
Aircraft Heading	Map Heading	None (Use GPS Track)	The GPS/FMS track will be used as the Map orientation reference.
		Synchro – no Heading Valid input	The EX500 will use ARINC 407 synchro input for heading information. The synchro source does not supply a “heading valid” signal, and the EX500 will assume the heading is valid whenever an excitation input is detected.
		Synchro – Heading Valid LOW	The EX500 will use ARINC 407 synchro input for heading information. The Heading Valid input is active when the signal is LOW.

System	Source	Values	Notes
		Synchro – Heading valid HIGH	The EX500 will use ARINC 407 synchro input for heading information. The Heading Valid input is active when the signal is HIGH.
		Stormscope	The EX500 will use the lightning sensor input for heading information. (WX500 must be configured for synchro)
		Traffic	The EX500 will use the traffic sensor input for heading information. (only present with TAS/TCAS sensors)
		GPS/FMS	The EX500 will use the GPS/FMS sensor ARINC 429 input for heading information. The GPS/FMS system may require supplemental signal converters to generate heading information usable to the EX500. Refer to GPS/FMS system installation manuals for configuration options.

Press **Save** to confirm changes made or press **Cancel** to retain previous system settings.

Figure 12 depicts the factory default settings for the Map system setup.

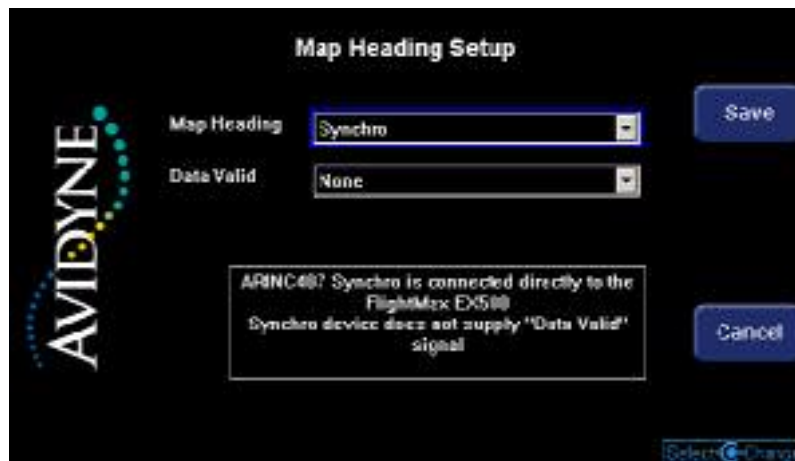

Figure 12: Map System Setup Page



### 3.11. Bezel Key Dimming Setup

From the **Aircraft Setup** page, the brightness of the EX500 bezel key backlighting can be balanced to the other aircraft components. With the cockpit in a darkened environment, perform the following procedure.

- Adjust the aircraft panel lighting control to maximum brightness.
- With the Brightest Dimming Voltage box highlighted, press **Set**
- Adjust the aircraft panel lighting control to minimum useable nighttime panel brightness.
  - NOTE: This brightness level should be at the point where any other panel instruments transition from dim (night) to bright (day) operation.
- **Select** the Darkest Dimming Voltage box.
- Press **Set**
- **Change** the setting value until the EX500 bezel key lighting matches other display-based instruments installed in the panel.
- Press **Save** to confirm changes made or press **Cancel** to retain previous system settings.



Figure 13: Aircraft Setup Screen

### 3.12. System Information

From the **MAINTENANCE MODE** main page the SYSTEM INFO pages may be accessed. Port assignments, platform information and datalink operating status is presented.

Verify sensor port assignments with the Port Info table.

Figure 14 depicts the Port Info table.

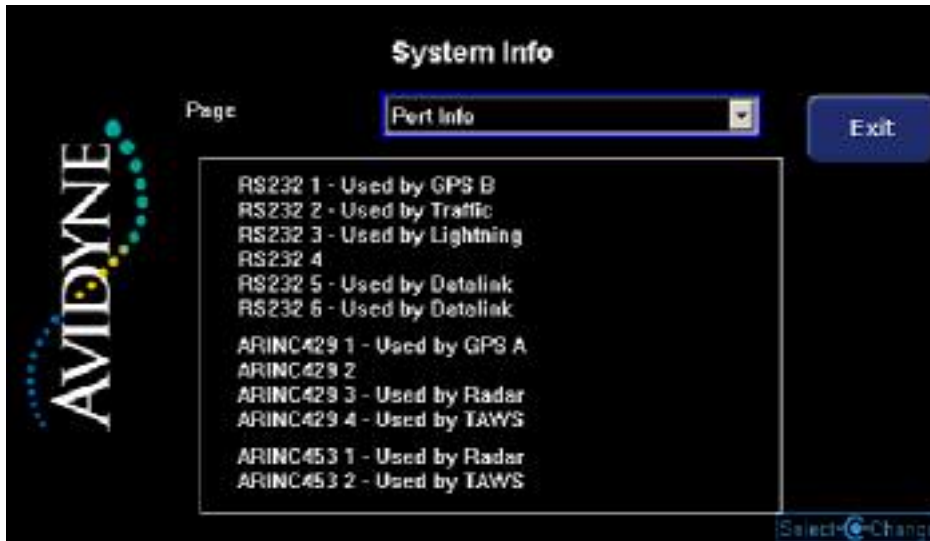

Figure 14: Port Info Table

Figure 15 depicts the Platform Info table.

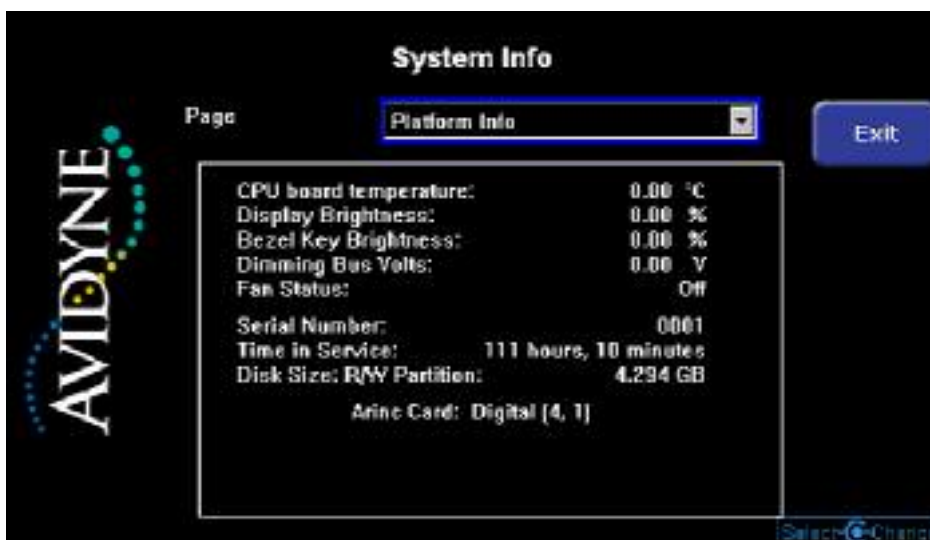

Figure 15: Platform Info Table

## 4. EX500 MFD Checkout

The following MFD checkout aides are intended to assure proper EX500 installation and interfacing with other aircraft sensors. Familiarize yourself with the Pilot's Guide for explanations of the various functions and display controls. Refer to AC20-68B Recommended Radiation Safety provided with the General Information section of this installation manual.

Any operational issues isolated to the EX500 MFD will require servicing of the unit by Avidyne authorized personnel. Refer to the return procedures located at the back of this installation manual for details.

### 4.1. Initial Installation Validation Test

Upon completion of aircraft wiring and tray installation, the following initial system validation should be performed.

- Check all power and airframe ground connections.
- Verify that power is not present on any pins other than those specified in the wiring diagrams section of this manual.
- Slide the MFD into its mounting tray.
- Verify that the MFD is properly seated in the mounting tray and secured into position.
- Lock the unit in place with a size 3/32" Allen wrench. If you need to remove the unit, unlock it with the Allen wrench, and slide the unit out of the tray.
- Apply power to the MFD and all associated sensors.

The unit will go through a start-up sequence, which should end with the display as represented in Figure 16.

- Verify the software revision number matches (or higher) that on the Section 2.1.
- Enter the **Maintenance Mode** per the procedure given in Section 3.1.1
- Verify that the sensor setup options per Section 3.2.1.

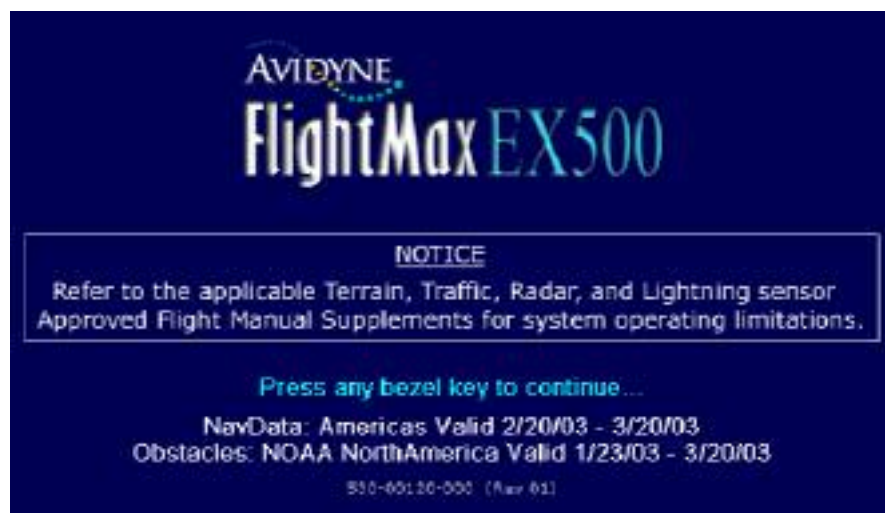

Figure 16: Start-up Screen

## 4.2. Sensor Communications Checkout

The following sections provide troubleshooting guidance when problems are encountered with EX500 MFD sensor interfaces. Please refer to the *EX500-Series Multi-Function Display Pilot's Guide* on the operation of each of these functions.

### 4.2.1. GPS/FMS Checkout

Turn on the GPS/FMS system and allow the time required to establish its present position. Insure the GPS/FMS system is properly configured for use with an MFD.

#### GPS/FMS Sensor Communications Troubleshooting

If there is a communication or data error between the navigation source and the MFD, one of the following messages will remain in the lower right corner of the screen.

<i>Message</i>	<i>Meaning/Action</i>
Nav Source Is Not Communicating	No RS 232 or ARINC 429 GPS data is being received. <ul style="list-style-type: none"> <li>○ Verify wiring and Comm port setting.</li> <li>○ Verify that the EX500 is properly seated in its tray.</li> </ul>
Nav Source Data Is Not Valid	Data is being received from the external GPS. However, insufficient information is available from the GPS to determine position. <ul style="list-style-type: none"> <li>○ Verify that the GPS has determined its "fix" or location (relocating the a/c outside of the hanger may assist reception)</li> <li>○ Verify GPS signal wiring within the harness.</li> </ul>
Nav Source Data Format Error	The MFD does not recognize the data being received from the GPS. <ul style="list-style-type: none"> <li>○ Verify GPS data rate or MFD receiver type set-up.</li> </ul>
Nav Source Can't Open Port (err=x)	The MFD is incorrectly setup with two devices on the same port. <p>2 = Device Not found, means that somehow they selected a port that doesn't exist. This may occur if they select an ARINC channel on a system without a radar board.</p> <p>5 = Either another sensor was configured with the same port or that ARINC1 was selected for the GPS on a non-ARINC 429 EX500.</p> <p>997 = I/O error, interference is inhibiting the EX500's ability to access the assigned port.</p> <ul style="list-style-type: none"> <li>○ From the Setup page, verify port assignments for sensor inputs. (Typically the GPS is configured for RS 232 Port 2 or ARINC 429 port 1)</li> </ul>
Nav Source Reconnecting ...	The data between the MFD and the GPS is being synchronized. (no action)
Heading Data Is Not Valid	When the GPS is being used as the heading source, heading data is no longer available from the GPS. <ul style="list-style-type: none"> <li>○ Verify that the GPS has determined its "fix" or location.</li> <li>○ Verify GPS reported heading matches aircraft heading.</li> <li>○ Verify heading into the GPS is valid</li> </ul>

#### 4.2.2. Lightning Sensor Checkout

Perform a functional test of the lightning detection system in accordance with manufacturer's instructions. Refer to the MFD Pilot Guide for display operation.

*Stabilization and heading location options must agree with the jumper settings on the WX500.*

#### **Lightning Sensor Communications Troubleshooting**

If there is a communication or data error between the lightning sensor and the MFD, one of the following messages will remain in the lower right corner of the screen.

<i>Message</i>	<i>Meaning/Action</i>
Lightning Sensor Error	<p>The sensor system has reported an error.</p> <ul style="list-style-type: none"> <li>○ Use WX500 Diagnostics and Self Test utilities on the EX500.</li> <li>○ Verify WX500 jumper wire configuration.</li> <li>○ Refer to lightning sensor installation and users manual to troubleshoot.</li> </ul>
Lightning Sensor Has Failed	<p>The sensor system has reported an error.</p> <ul style="list-style-type: none"> <li>○ Use WX500 Diagnostics and Self Test utilities on the EX500</li> <li>○ Refer to lightning sensor installation and users manual to troubleshoot.</li> </ul>
Lightning Sensor Is Not Communicating	<p>Communication of strike data from the lightning sensor to the MFD has been lost.</p> <ul style="list-style-type: none"> <li>○ Verify that the sensor is turned on and valid.</li> <li>○ Verify that the EX500 is properly seat in its tray.</li> <li>○ Verify system wiring.</li> </ul>
Lightning Heading Source Failed	<p>When the lightning sensor is being used as the heading source, heading data is no longer available from the sensor.</p> <ul style="list-style-type: none"> <li>○ Verify system wiring (incl. synchro).</li> <li>○ Use WX500 Diagnostics and Self Test utilities on the EX500</li> <li>○ Refer to lightning sensor installation and users manual to troubleshoot.</li> </ul>
Lightning –Antenna Location Changed	<p>Present when the antenna installation configuration between the MFD and the WX500 is different.</p> <ul style="list-style-type: none"> <li>○ Verify WX500 antenna location on the aircraft.</li> <li>○ Verify WX500 antenna location configuration (jumper).</li> <li>○ Verify (from EX500 Maintenance Mode) "Lightning Setup Antenna on Top?" checkbox setting.</li> </ul> <p style="text-align: center;">(All three should agree)</p>

For details on other errors and parameters sent by the lightning sensor, refer to the lightning sensor installation and users manuals.

#### 4.2.3. Traffic Sensor Checkout

##### **4.2.3.1. TCAS I Checkout**

Perform a functional test of the TCAS system in accordance with manufacturer's instructions. Refer to the MFD Pilot Guide for display operation.

If the self-test fails, test traffic displayed will not be visible or an error message is generated and displayed on the EX500 display.

Refer to the TCAS installation manual for explanations and fault isolation procedures.

##### **4.2.3.2. Skywatch TAS Checkout**

Perform a functional test of the Skywatch TAS in accordance with manufacturer's instructions. If a WX-1000 display unit is not installed, refer to the MFD Pilot Guide for display operation.

If the self-test fails, an error message is generated and displayed on the EX500 display. Refer to the Skywatch TAS installation manual for explanations and fault isolation procedures.

##### **4.2.3.3. Honeywell TAS Checkout**

Perform a functional test of the TAS system in accordance with manufacturer's instructions. Refer to the MFD Pilot Guide for display operation.

If the self-test fails, an error message is generated and displayed on the EX500 display. Refer to the KTA-870 and KMH-880 installation manuals for explanations and fault isolation procedures.

##### **4.2.3.4. 9900BX TAS Checkout**

Perform the checkout procedures of the 9900BX TAS in accordance with manufacturer's instructions. If a Ryan traffic display unit is not installed, refer to the MFD Pilot Guide for display operation.

If the self-test fails, an error message is generated and displayed on the EX500 display. Refer to the 9900BX TAS installation manual for explanations and fault isolation procedures.

##### **4.2.3.5. 9900B TCAD Checkout**

Perform the checkout procedures of the 9900B TCAD in accordance with manufacturer's instructions. The EX500 does not display the TCAD self test function. If you wish to perform this test then you must use the Ryan TCAD display unit.

If the self-test fails, an error message is generated and displayed on the EX500 display. Refer to the 9900B TCAD installation manual for explanations and fault isolation procedures.

### Traffic Sensor Communications Troubleshooting

If there is a communication or data error between the traffic sensor and the MFD, one of the following messages will remain in the lower right corner of the screen.

<i>Message</i>	<i>Meaning/Action</i>
Traffic Sensor Is Not Communicating	<p>The traffic sensor is reporting a failure condition or not receiving valid data.</p> <ul style="list-style-type: none"> <li>○ Verify that the EX500 is properly seat in its tray.</li> <li>○ Verify system wiring.</li> <li>○ Refer to traffic system installation and users manual to troubleshoot.</li> </ul>
Traffic Sensor has FAILED {TCAD}	<p>The EX500 RS232 ports are not configured correctly.</p> <ul style="list-style-type: none"> <li>○ Verify EX500 sensor ports do not conflict.</li> </ul>
Traffic can't connect {TCAS, TAS}	<p>The EX500 ARINC429 ports are not configured correctly.</p> <ul style="list-style-type: none"> <li>○ Verify EX500 sensor ports do not conflict.</li> </ul>
TCAD Altitude Unavailable {TCAD}	<p>Altitude data is not being received from the traffic sensor.</p> <ul style="list-style-type: none"> <li>○ Verify that the sensor is turned on and valid.</li> <li>○ Verify system wiring (incl. alt. encoder).</li> <li>○ Refer to traffic sensor installation and users manual to troubleshoot.</li> </ul>
Traffic Heading Source Is Not Valid {TCAS, TAS}	<p>When the traffic sensor is being used as the heading source, heading data is no longer available from the sensor.</p> <ul style="list-style-type: none"> <li>○ Verify system wiring (incl. synchro).</li> <li>○ Refer to traffic sensor installation and users manual to troubleshoot.</li> </ul>

#### 4.2.4. TAWS Checkout

##### 4.2.4.1. EGPWS Checkout

With the EX500 selected to the TAWS page, perform a functional test of the EGPWS system in accordance with manufacturer’s instructions. Refer to the MFD Pilot Guide for display operation.

The EGPWS software must support KC Picture Bus (KCPB) Phase 2. Consult the Honeywell EGPWS documentation for applicable software configurations. Proper operation of the EGPWS interface is noted by the absence of any system status messages. If the self-test fails, an error message is generated and displayed on the EX500 display. Refer to the EGPWS system installation manual for explanations and fault isolation procedures.

#### **TAWS Communications Troubleshooting**

If there is a communication or data error between the TAWS sensor and the MFD, the following message will remain on the bottom of the screen.

<i>Message</i>	<i>Meaning/Action</i>
TAWS Display Failed	An incorrect system configuration or failure in one of the system components has occurred. <ul style="list-style-type: none"> <li>○ Verify that the sensor is turned on and valid.</li> <li>○ Verify system wiring.</li> </ul>
TAWS Display Initializing	If message does not clear within 60 seconds, communication between the EX500 and the Terrain sensor has not been established. <ul style="list-style-type: none"> <li>○ Verify that the sensor is turned on and valid.</li> <li>○ Verify system wiring.</li> <li>○ Refer to terrain sensor installation and user’s manual to troubleshoot.</li> </ul>
TAWS Not Communicating	Indicates that the EX500 is not receiving data from the Terrain sensor. <ul style="list-style-type: none"> <li>○ Verify that the sensor is turned on and valid.</li> <li>○ Verify system wiring.</li> <li>○ Refer to TAWS sensor installation and user’s manual to troubleshoot.</li> </ul>
TAWS Display Unavailable	The TAWS Sensor has declared itself inoperative. <ul style="list-style-type: none"> <li>○ Verify system wiring.</li> <li>○ Verify that the sensor inputs to the TAWS are turned on and valid.</li> <li>○ Refer to TAWS sensor installation and user’s manual to troubleshoot.</li> </ul>
TAWS Sensor Self-Test	The TAWS Sensor is performing a Self-Test. The message will remain until the self-test is finished. <ul style="list-style-type: none"> <li>○ Verify that the “Self-Test” mode has been not been selected at the separate TAWS control panel.</li> <li>○ Verify system wiring.</li> <li>○ Refer to TAWS sensor installation and user’s manual to troubleshoot.</li> </ul>
TAWS Display Inhibited	The TAWS sensor is in the “Self-Test” mode. <ul style="list-style-type: none"> <li>○ Verify that the “Self-Test” mode has been not been selected at the separate TAWS control panel.</li> <li>○ Verify system wiring.</li> <li>○ Refer to TAWS sensor installation and user’s manual to troubleshoot.</li> </ul>



#### 4.2.5. RADAR Checkout

Perform a functional test of the RADAR system in accordance with manufacturers instructions. Refer to the MFD Pilot Guide for display operation.

##### 4.2.5.1. RADAR Sensor Communications Troubleshooting

If there is a communication or data error between the RADAR sensor and the MFD, the following message will remain on the bottom of the screen.

<i>Message</i>	<i>Meaning/Action</i>
Radar Sensor Data Is Invalid	<p>Data received from the RADAR sensor system can not be used by the EX500</p> <ul style="list-style-type: none"> <li>○ Cycle power on the EX500.</li> <li>○ Refer to RADAR Sensor installation and users manual to troubleshoot.</li> </ul>
Radar Sensor Has Failed	<p>The RADAR sensor system has reported an error.</p> <ul style="list-style-type: none"> <li>○ Check R/T configuration module error log.</li> <li>○ Refer to RADAR Sensor installation and users manual to troubleshoot.</li> </ul>
Radar Sensor Is Not Communicating	<p>Communication of return data from the RADAR sensor to the MFD has been lost.</p> <ul style="list-style-type: none"> <li>○ Verify that the RADAR sensor is turned on and valid.</li> <li>○ Verify that the EX500 is properly seat in its tray.</li> <li>○ Verify system wiring.</li> </ul>
Invalid GPS Data and Radar is ON	<p>The RADAR is ON and the EX500 has no ground speed data available from the GPS/FMS.</p> <ul style="list-style-type: none"> <li>○ Verify the GPS/FMS is ON and valid.</li> <li>○ Verify system wiring.</li> <li>○ Refer to RADAR Sensor installation and users manual to troubleshoot.</li> </ul>
Radar Automatic Standby Disabled	<p>The RADAR is ON, the EX500 RADAR automatic standby mode is disabled, and the EX500 has no ground speed data available from the GPS/FMS.</p> <ul style="list-style-type: none"> <li>○ Verify the GPS/FMS is ON and valid.</li> <li>○ Verify system wiring.</li> <li>○ Refer to RADAR Sensor installation and users manual to troubleshoot.</li> </ul>

#### 4.2.6. Narrowcast Datalink Checkout

Refer to the MFD Pilot Guide for datalink related display configuration and operation.

##### 4.2.6.1. Communications Troubleshooting

If there is an internal communication or data error between the satellite transceiver and the MFD main processor, the following message will remain on the bottom of the screen.

<i>Message</i>	<i>Meaning/Action</i>
Datalink Sensor Data Is Invalid	The EX500 has received unreadable satellite data. <ul style="list-style-type: none"> <li>○ Verify that the EX500 is properly seated in its tray.</li> </ul>
Datalink Sensor Configuration Error	The EX500 Comm Ports are improperly configured for datalink. <ul style="list-style-type: none"> <li>○ Requires factory servicing. Refer to Factory Service Policies section of this manual.</li> </ul>
Datalink Sensor Is NOT Communicating	The EX500 is experiencing a communication failure with the internal Satellite transceiver. <ul style="list-style-type: none"> <li>○ Requires factory servicing. Refer to Factory Service Policies section of this manual.</li> </ul>

##### 4.2.6.2. Reception Troubleshooting

The ORBCOMM satellite network transmits very low power VHF signals that the EX500 must receive. If the antenna is not properly installed or if there is excessive electromagnetic interference (such as by nearby radio transmitter or inadequately grounded electronics) the system will not achieve successful reception. The following steps may be taken to assess system performance.

- Bring the aircraft to an area that has as few obstacles to line-of-sight viewing to the southern horizon as possible and orient the aircraft heading south.
- From Datalink Info table (see Figure 11), monitor for up to five minutes under the following conditions; other avionics off, avionics on, engines at idle, engines at takeoff power. With a satellite in view the signal strength and quality should peak above the following values.
  - "Signal strength" is greater than -118 dBm
  - "Estimated SNR (EbNo)" is greater than 10 dB
  - "Segment errors" less than 10%

If the above reception levels are not achieved the following cause and corrective actions may apply.

- The antenna field of view is obstructed. Try moving or rotating the aircraft.  
(if rotation works the antenna location on the aircraft may not be optimal.)
- There is a local source of electromagnetic interference.
  - Try shutting off any nearby sources (such as VHF radios, alternators and magnetos).
  - Relocated the aircraft away from potential nearby sources.
  - Check electrical connections to ensure there is no improper grounding.
- There is poor satellite coverage. Try again after fifteen minutes.
- The antenna and cable are not properly installed.
  - The antenna may not be properly connected to the ground plane. There must be less than 0.003 Ohms between the antenna mounting screw and the aircraft skin for proper grounding.

The cable may not be properly connected to the antenna or EX500 tray.

The following worksheet will assist in characterizing and troubleshooting the Narrowcast datalink transceiver installation. The ORBCOMM satellite network transmits very low power VHF signals that the EX500 must receive. If the antenna is not properly installed or if there is excessive electromagnetic interference (such as by nearby radio transmitter or inadequately grounded electronics) the system will not achieve successful reception.

The following steps may be taken to assess system performance.

- Bring the aircraft to an area that has as few obstacles to line-of-sight viewing to the southern horizon as possible and orient the aircraft heading south.
- From the Maintenance Mode SYSTEM INFO page access the Datalink Info table (EX500 Installation Manual Section 3.8.1), monitor for up to fifteen minutes under the following conditions and record the peak values indicated on the EX500.

	Signal Strength > -118 dBm	Estimated SNR (EbNo) > 10 dB	Segment Errors <10%
- All avionics OFF	_____	_____	_____
		Estimated SNR (EbNo) > 10 dB	Segment Errors <10%
- Electronic Instruments ON		_____	_____
- Only Navigation Lights, Strobes and Beacons ON		_____	_____
- Transponder ON (and in ALT mode when available)		_____	_____
- COM 1 ON		_____	_____
- COM 2 ON		_____	_____
- Other Radios ON (ADF, DME, etc.)		_____	_____
- Fuel Pumps ON (test individually when possible)		_____	_____
- Pitot heat ON		_____	_____
- Windshield Heat ON		_____	_____
- Windshield Wipers ON		_____	_____
- Engine ON and at IDLE		_____	_____
- Left Magneto OFF		_____	_____
- Right Magneto OFF		_____	_____
- Engine at TAKEOFF POWER		_____	_____

If the reception levels listed above are not achieved, troubleshoot the installation of the offending system (ex. COM 2) and insure that proper shield terminations are made and adequate harness separation exists on the aircraft. Additional shielding of the antenna coax cable will often improve system reception performance. Excessive aircraft ignition noise may stem from Magnetos or Ignition system wiring.

Consult [www.avidyne.com](http://www.avidyne.com) for any additional guidance.

Due to the weak signal levels of the satellite-based communication network, the datalink system is very sensitive to electrical noise that may be present on the aircraft. These noise sources include:

- Radio transmitters – VHF Communications, Transponders
- Ignition/Electrical systems – Magnetos, Alternators

If the signal level, estimated SNR and segment error values achieve the recommended values listed in Section 3.8 with no other equipment powered on the aircraft and engine not running, but fails in one or more of the other test conditions, then aircraft noise interference is likely. With the datalink system active, selectively turning on other equipment and systems one piece at a time can help isolate the source of datalink interference. Once identified, the suspect system, and its associated harnessing, should be inspected for proper electrical bonding (grounding). In some cases (ex. magnetos), additional harness shielding may be required.

#### **4.2.6.3. Interference Troubleshooting**

The Narrowcast datalink transceiver is wired to its antenna with a double-shielded coax (RG400) cable. This shielding design reduces the chances of interference between the datalink system and other aircraft systems. Care should be taken when selecting where to route the cable from the EX500 to the antenna. Placing the Narrowcast datalink coax cable away from non-shielded wires and sensitive systems (ex. analog flight director signals, radio receivers, etc.) will reduce the chances of interference. Additional shielding may prove necessary where the datalink system is seen to interfere with other aircraft systems and cable routing modifications are not possible or prove ineffective.

#### 4.2.7. Broadcast Datalink Checkout

Start the MFD and select the Trip page. Press the Display button to view Broadcast Status (down pointing arrow). If the MFD reports a Receiver ID the receiver is communicating with the MFD and the RS-232 wiring is correct.

Position the aircraft in an area open to the sky. A Signal Quality of Good confirms the receiver is detecting the satellite signals. A Signal Quality of Marginal or Weak may require repositioning the aircraft to better location. A Signal Quality of None is an indication of a bad antenna, cable, connection or receiver.

After the MFD has been restarted, any of the following messages may appear in the message bar on any page and in the message list on the Setup page.

<i>Message</i>	<i>Meaning</i>
Broadcast is Operating Normally	Verification that the MFD is communicating with the Broadcast receiver
Broadcast is Not Communicating (After 5 minutes of no communication)	The MFD is not communicating with the Broadcast receiver. Check power and wiring.

#### 4.2.8. Broadcast Datalink Satellite Reception Confirmation

The broadcast satellite network transmits signals that are received by an external datalink receiver, which sends the information on to the MFD through a serial connection. If the datalink antenna is not properly installed or if there is excessive electromagnetic interference (such as a nearby radio transmitter or inadequately grounded electronics), the system will not achieve consistent reception. The following steps may be taken to assess system performance:

- Bring the aircraft to an area that has as few obstacles to line-of-sight viewing to the southern horizon as possible.
- Select the Trip page on the MFD.
- Press the Display button until Broadcast (down-pointing arrow) Status is selected.
- The Signal Quality will be reported as Good, Marginal, Weak, or None. If the Broadcast Receiver is working, the antenna and cabling are correct, and the aircraft is in view of at least one Broadcast datalink satellite, the Signal Quality will be “Good” and the Receiver ID will be reported.
- Make note of the Receiver ID for the aircraft owner, who will need it to begin Broadcast datalink service.

If the Signal Quality is not reported as Good, the following cause and corrective actions may apply.

- The antenna field of view is obstructed. Try moving or rotating the aircraft.
- Note: if rotation works, the antenna location on the aircraft may not be optimal
- There is a local source of electromagnetic interference.
    - Try shutting off any nearby sources (such as VHF radios, alternators and magnetos).
    - Relocate the aircraft away from potential nearby sources.
    - Check electrical connections to ensure there is no improper grounding.
    - The antenna and cable are not properly installed.
    - The antenna may not be properly connected to the ground plane.

- The cable may not be properly connected to the antenna or the EX5000.

Consult [www.avidyne.com](http://www.avidyne.com) for any additional guidance.

#### 4.2.9. Synchro Heading Checkout

With the EX500 powered and operating, and the EX500 heading source set to synchro (ref. Section 3.9), verify the heading displayed on the **Map** page matches the actual aircraft heading.

**Important:** The EX500 **MUST** be receiving GPS position in order to display heading. If GPS position is not valid, magnetic heading will be display as three dashes (“---”).

##### 4.2.9.1. Heading Source Troubleshooting

If there is a data error between the aircraft heading synchro source and the MFD, the following message will remain on the bottom of the screen.

<i>Message</i>	<i>Possible Cause</i>	<i>Action</i>
Synchro Heading is NOT Valid	No 400 Hz excitation on REF HI “Heading Valid” is inactive or incorrectly specified	Verify synchro excitation If a “Heading Valid” input is connected from the heading source, ensure: The proper active level has been selected (Section 3.9) External series resistor R1 has been installed (Appendix F)

\*When using the EX500's direct synchro interface, the following table can be used to troubleshoot and correct wiring errors. If it is determined that the X, Y, or Z lines are incorrectly connected, **BE SURE TO SWAP THE APPROPRIATE LINES AT THE EX500**. Swapping lines at the synchro source could result in unintentional heading problems with other devices connected to the aircraft heading system.

\*In addition, only use the following table if heading is continuously present on the EX500 with incorrect readings. If the heading display is intermittent or blank, then all five synchro lines should first be checked for continuity and shorts.

\*If no continuity errors or shorts are present in the system, use the manual slew feature of the aircraft's compass system to position the H.S.I. at 0, 120, and 240 degrees.

Write down the corresponding EX500 heading readings and then use the following table to correct the wiring.

<b>Compass System Reading</b>	<b>EX500 Reading</b>	<b>Error Amount</b>	<b>Problem</b>	<b>Solution</b>
0	0	0		
120	240	+120	X and Y Crossed	Swap X and Y
240	120	-120		
0	240	-120	X and Z Crossed	Swap X and Z
120	120	0		
240	0	+120		
0	120	+120	Y and Z Crossed	Swap Y and Z
120	0	-120		
240	240	0		
0	240	-120	YZX Cross	Swap Y and Z, then swap X and Y
120	0	-120		
240	120	-120		
0	120	+120	ZXY Cross	Swap X and Y, then swap Y and Z
120	240	+120		
240	0	+120		
0	180	180	Ref HI and Ref LO reversed	Swap Ref HI and Ref LO

### 4.3. Post Installation Check EMI Check

The following procedure is performed to verify that no interference is noted through the use of the EX500 MFD on other systems in the aircraft. The operation of the EX500 MFD shall not result in Nav flags, constant location lightning strikes on any installed Stormscope, noise on COMM channels, or other phenomena.

#### Comm Radios:

- Scan through radio channels to ensure there is no interference caused by the EX500 or no break in squelch due to the installation.
- Check local ground and tower frequencies to ensure there is no break in squelch due to the installation.

#### GPS:

- Ensure that correct position is displayed
- Verify no change in satellite signal strength on the GPS receiver with EX500 unit powered ON or OFF.

#### Autopilot:

- Ensure that autopilot self-test passes OK with EX500 powered on.

#### Other Instruments:

- Verify that there is no adverse effect on other instruments with EX500 powered ON

## 5. MFD Data Updates

### 5.1. Map NavData Database Updates

The Map NavData database may be updated periodically with data purchased from Jeppesen, [www.jeppesen.com](http://www.jeppesen.com).

All MFD units are shipped with the latest database pre-loaded. There are two places to check the expiration date or version number:

- The Startup Screen
- The Setup Page

Updates are available via an optional Data Loader that connects to the Data Loader (USB) port on the front of the MFD.

#### 5.1.1. To perform a data update

1. Turn power OFF to the MFD.
2. Install data disk into the Data Loader drive.
3. Connect one end of the interconnect cable to the Data Loader and the other end to the MFD data port on the front panel of the MFD.

**NOTE:** Ensure that the Data Loader is supported and not dangling by the cable. This may cause an intermittent connection, which will result in an unsuccessful data update.

4. Apply power to the MFD.
5. The Data Loader screen is displayed.

**NOTE:** If the regular MFD startup screen with the “Press Any Bezel Key” message is displayed, the Data Loader was not detected by the MFD. Check the connection between the Data Loader and the MFD. Cycle power to the MFD.

6. Press the “Proceed” button. Do not turn off the MFD or disconnect the interconnect cable during a data load.
7. The data load is complete when the “Press Any Bezel Key” message is displayed.
8. Remove the Data Loader and interconnect cable and store in a safe place.

### 5.2. Chart Database Updates

The database of terminal procedure charts must be updated periodically with data purchased via subscription from Jeppesen, [www.jeppesen.com](http://www.jeppesen.com).

MFD units are shipped without any chart data pre-loaded. It is up to the user to obtain a valid subscription from Jeppesen. Once the user has a valid Jeppesen subscription serial number, they should visit [www.myAvidyne.com](http://www.myAvidyne.com) to obtain an Avidyne Key number, which will allow use of that subscription on a certain MFD. The user will have to register their MFD with [myAvidyne.com](http://myAvidyne.com) if they have not already done so. Both the Jeppesen subscription number and the Avidyne Key number are required to complete a chart data load.

There are two places to check the expiration date of the chart data:

- The Startup Screen
- The Setup Page

Updates are loaded via an optional Data Loader that connects to the Data Loader (USB) port on the front of the MFD.

Once the user has both a Jeppesen subscription number and Avidyne Key number, they can run the Avidyne Data Extractor program on their PC to extract their chart data from the Jeppesen CD-ROM



and save it onto a disk in the Avidyne Dataloader device. The Avidyne Dataloader is then ready to complete the chart update.

**NOTE:** For more information on running Avidyne Data Extractor, consult Avidyne 600-00114-000, *Avidyne CMax Data Update Guide*

#### 5.2.1. To perform a chart data update

1. Turn power OFF to the MFD.
2. Install data disk into the Data Loader drive.
3. Connect one end of the interconnect cable to the Data Loader and the other end to the MFD data port on the front panel of the MFD.

**NOTE:** Ensure that the Data Loader is supported and not dangling by the cable. This could cause an intermittent connection, which will result in an unsuccessful data update. Cycle power to the MFD.

4. Apply power to the MFD.
5. The Data Loader screen is displayed.

**NOTE:** If the regular MFD startup screen with the “Press Any Bezel Key” message is displayed, the Data Loader was not detected by the MFD. Check the connection between the Data Loader and the MFD.

6. Press the “Proceed” button. Do not turn off the MFD or disconnect the interconnect cable during a data load.
7. The data load is complete when the normal startup screen with the “Press Any Bezel Key” message is displayed.
8. Remove the Data Loader and interconnect cable and store in a safe place.



## 6. Factory Service Policies

### 6.1. Technical Support

Avidyne's web site contains information that may assist the operator and installer with questions or problems with their FlightMax EX500-Series Multi-Function Display.

**www.avidyne.com**

Technical support questions may be submitted, 24 hours per day, via the following:

**Email: [techsupport@avidyne.com](mailto:techsupport@avidyne.com)**

**Fax: 781-402-7599**

**Voice: 888-723-7592**

An Avidyne technical support representative will respond as soon as possible. Avidyne business hours are 8:00 AM to 5:00 PM Eastern Time, Monday through Friday.

Please include the part number, revision number and serial number of the unit in all correspondences. For problem reporting, please provide as many details associated with the problem as possible.

### 6.2. General Service Procedures

Repair of the EX500 is performed at the factory, and includes a complete checkout and recalibration.

Prior to returning a unit for service, contact Avidyne at 888-723-7592 to obtain a Return Merchandise Authorization (RMA) number.

Securely pack the unit in the original Avidyne shipping carton, write the RMA number on the outside of the carton, and return it to the address provided by the Avidyne Customer Service Representative.

Include your name, complete shipping address, daytime telephone number, a complete description of the problem, the desired return date, and shipping method.

If the original shipping carton or other suitable foam packing is not available, contact Avidyne to arrange for packaging materials. Avidyne is not responsible for damage due to poorly packaged returns.

### 6.3. AC 20-68B Recommended Radiation Safety

DEPARTMENT OF TRANSPORTATION  
FEDERAL AVIATION ADMINISTRATION  
WASHINGTON, D.C.

PURPOSE. This circular sets forth recommended radiation safety precautions to be taken by personnel when operating airborne weather radar on the ground.

1. CANCELLATION. AC20-68, dated April 11, 1975, is cancelled.

2. RELATED READING MATERIAL:

Barnes and Taylor, Radiation Hazard and Protection (London: George Newnes Limited, 1963), p.211.

U.S. Department of Health, Education and Welfare, Public Health Service, Consumer Protection and Environmental Health Service, "Environmental health microwaves, ultraviolet radiation and radiation from lasers and television receivers - An Annotated Bibliography," FS 2.300: RH-35, Washington, U.S. Government Printing Office, pp. 56-57.

Mumford. W.W., "Some technical aspects of microwave radiation hazards," Proceedings of the IRE, Washington, U.S. Government Printing Office, February 1961, pp. 427-447.

1. BACKGROUND. Dangers from ground operation of airborne weather radar include the possibility of human body damage and ignition of combustible material by radiated energy. Low tolerance parts of the body include the eyes and testes.
2. PRECAUTIONS. Management and supervisory personnel should establish procedures for advising personnel of dangers from operating airborne weather radars on the ground. Precautionary signs should be displayed in affected areas to alert personnel of ground testing.

General.

Airborne weather radar should be operated on the ground only by qualified personnel.

1. Installed airborne radar should not be operated while the aircraft is in a hangar or other enclosure unless the radar transmitter is not operating, or the energy is directed toward an absorption shield which dissipates the radio frequency energy. Otherwise, radiation within the enclosure can be reflected throughout the area.
2. Body Damage. To prevent possible human body damage, the following precautions should be taken.  
Personal should never stand nearby and in front of a radar antenna which is transmitting. When the antenna is not scanning, the danger increases.
3. A recommended safe distance from operating airborne weather radars should be established. A safe distance can be determined by using the equation in Appendix 1 or the graphs of figures 1 and 2. This criterion is now accepted by many industrial organizations and is based on limiting exposure of humans to an average power density not greater than 10 milliwatts per square centimeter.
4. Personnel should be advised to avoid the end of an open waveguide unless the radar is turned off.
5. Personnel should be advised to avoid looking into the waveguide, or into the open end of a coaxial connector or line connector to a radar transmitter output, as severe eye damage may result.
6. Personnel should be advised that when high power radar transmitters are operated out of their protective cases, X-rays may be emitted. Stray X-rays may emanate from the glass envelope type pulser, oscillator, clipper, or rectifier tubes, as well as magnetrons.
7. Combustible Materials. To prevent possible fuel ignition, an installed airborne weather radar should not be operated while an aircraft is being refueled or defueled.

M.C. BEARD  
Director of Airworthiness

Appendix A Environmental Qualification Forms

**RTCA/DO-160D ENVIRONMENTAL QUALIFICATION FORM**

NOMENCLATURE:	EX500 Multi-Function Display
PART NO:	700-00007-XXX-()
TSO NUMBER	C113, C63c, C118, C110a, C147
MANUFACTURER:	AVIDYNE CORPORATION
ADDRESS:	55 OLD BEDFORD ROAD, LINCOLN, MA 01773

CONDITIONS	RTCA/DO-160D PARAGRAPH	CONDUCTED TEST CATEGORY
TEMPERATURE	4.5	D1
INFLIGHT LOSS OF COOLING	4.5.4	V,D1
ALTITUDE	4.6.1	D1
DECOMPRESSION	4.6.2	D1
OVERPRESSURE	4.6.3	D1
TEMPERATURE VARIATION	5.0	B
HUMIDITY	6.0	A
OPERATIONAL SHOCK	7.2	B
CRASH SAFETY	7.3	B
VIBRATION	8.0	Cat. S Curves M
EXPLOSION	9.0	X (Not Tested)
WATERPROOFNESS	10.0	X (Not Tested)
FLUIDS SUSCEPTIBILITY	11.0	X (Not Tested)
SAND AND DUST	12.0	X (Not Tested)
FUNGUS	13.0	X (Not Tested)
SALT SPRAY	14.0	X (Not Tested)
MAGNETIC EFFECT	15.0	Z
POWER INPUT	16.0	B
VOLTAGE SPIKE	17.0	A
AUDIO FREQUENCY CONDUCTED SUSCEPTIBILITY	18.0	Z
INDUCED SIGNAL SUSCEPTIBILITY	19.0	A
RADIO FREQUENCY SUSCEPTIBILITY	20.0	V
EMISSION OF RADIO FREQUENCY ENERGY	21.0	M
LIGHTNING INDUCED TRANSIENT SUSCEPTIBILITY	22.0	A3E3
LIGHTNING DIRECT EFFECTS	23.0	X (Not Tested)
ICING	24.0	X (Not Tested)
ELECTROSTATIC DISCHARGE	25.0	A

## Appendix B STC EX500 Permission

Avidyne Corporation hereby grants permission to all National Aviation Authority (FAA, CAA, JAA) approved installers to use data from STC SA00161BO and amendments to modify aircrafts. The latest version of the associated AVMFC-076 Avidyne 700-0007-XXX-() MFD (EX500) Approved Model List may be accessed by authorized dealers at [www.avidyne.com](http://www.avidyne.com). Copies of the STC and amendments follow:

United States Of America  
Department of Transportation - Federal Aviation Administration

# Supplemental Type Certificate

*Number* SA00161BO

*This Certificate issued to* Avidyne Corporation  
55 Old Bedford Road  
Lincoln, Massachusetts 01773

*certifies that the change in the type design for the following product with the limitations and conditions therefore as specified herein meets the airworthiness requirements of Part 23 of the Federal Aviation Regulations.*

*Original Product Type Certificate Number :* See attached FAA Approved Model List (AME), Document No. AVMFC-076, Rev (D), dated February 08, 2005, or later FAA approved revisions for the list of approved airplane models and applicable regulations.  
*Make :*  
*Model :*

*Description of Type Design Change:*  
Installation of Avidyne Corporation FlightMax 700-00007-() EX500 Multi-Function Display in accordance with Avidyne Corporation Master Document List, Document No. AVMFD-088, Revision 09, dated February 4, 2005, or later FAA-approved revisions.

*Limitations and Conditions:*

1. The FlightMax EX500 Multi-Function Display integrates with separately approved system installations. Adherence to the limitations in the appropriate Aircraft Flight Manual Supplements for those systems is mandatory.
2. Instructions for Continued Airworthiness (ICA), Avidyne Corporation Document AVMFD-083, Revision 05, dated October 15, 2004 or later FAA accepted revision shall be made available to the operator at the time of installation.
3. Compatibility of this design with previously approved modifications must be determined by the installer.

If the holder agrees to permit another person to use this certificate to alter the product, the holder shall give the other person written evidence of that permission.

*This certificate and the supporting data which is the basis for approval shall remain in effect until surrendered, suspended, revoked or a termination date is otherwise established by the Administrator of the Federal Aviation Administration.*

*Date of application :* September 10, 2002  
*Date of issuance :* February 6, 2003

*Date received :*  
*Date amended :* February 8, 2003

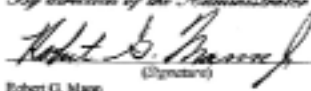

*By direction of the Administrator*  
  
(Signature)  
Robert G. Mann  
Manager  
Boston Aircraft Certification Office

(TW)

Any alteration of this certificate is punishable by a fine of not exceeding \$1,000, or imprisonment not exceeding 1 year, or both.  
FAA Form 3363-112-02 Page 1 of 1 This certificate may be reclassified in accordance with FAR 21.47.

Appendix C Installation Mechanical: MFD, Tray & Panel Dimensions

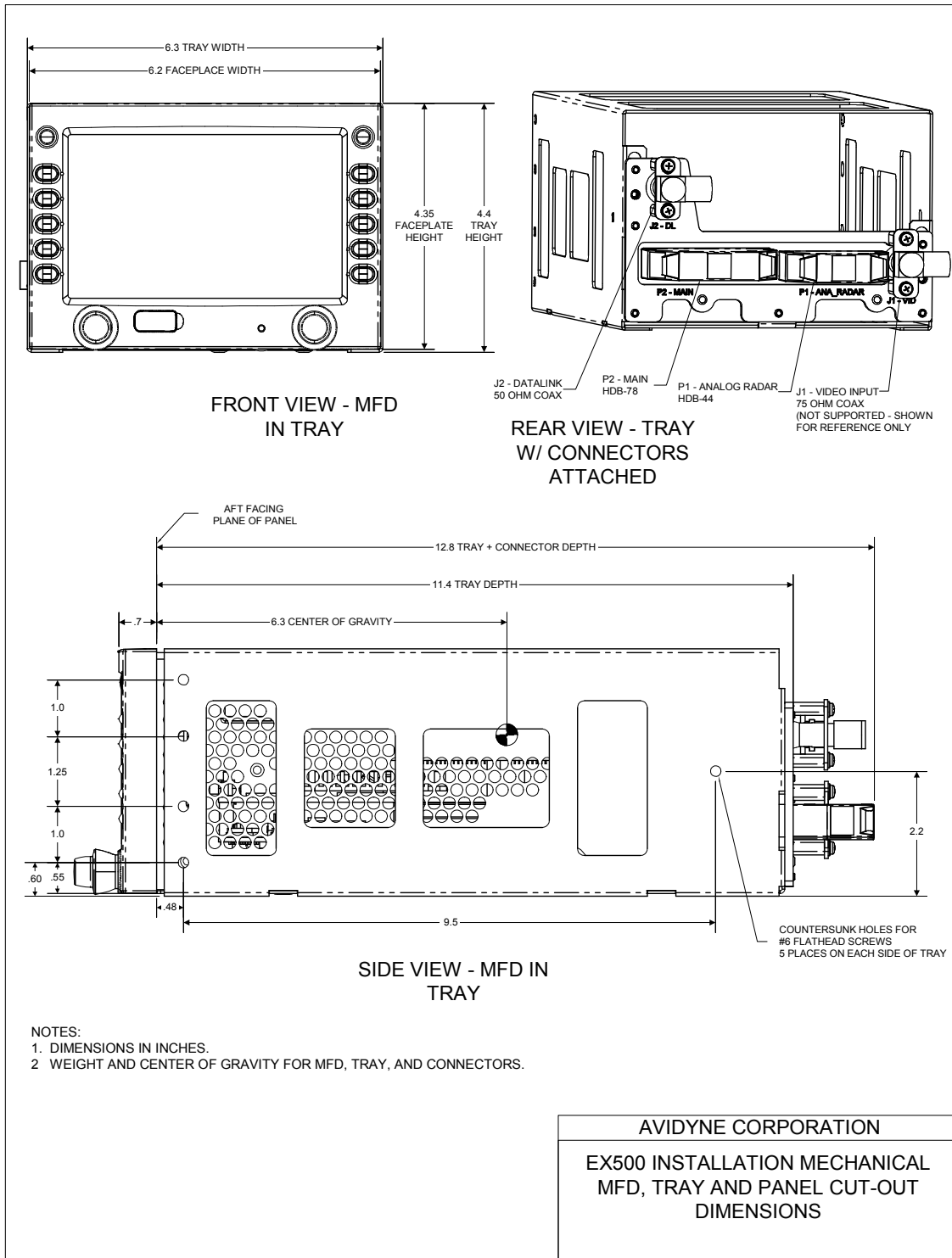

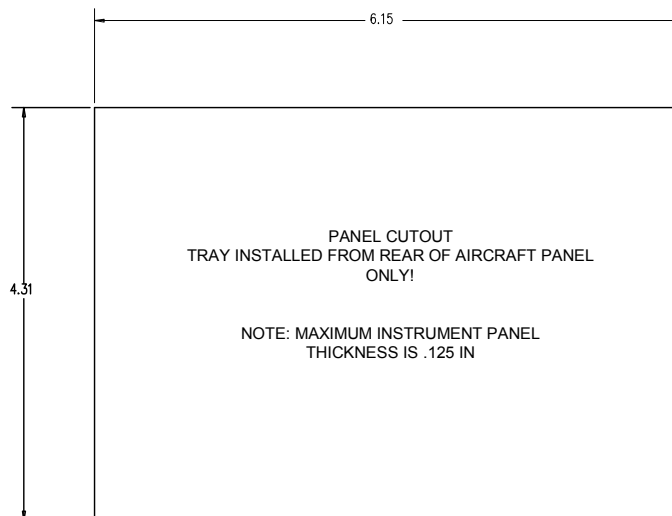
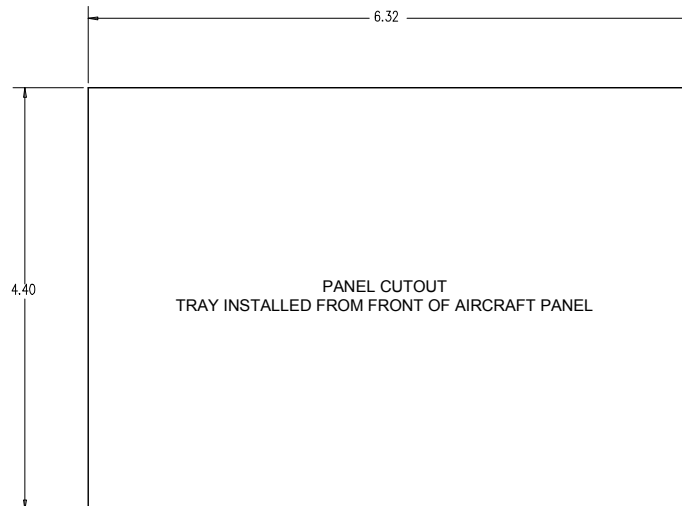

**NOTES:**

1. DIMENSIONS IN INCHES.
2. FOR ALL TYPES OF INSTALLATION, IF THE REAR FACE OF THE EX500 BEZEL/FACEPLATE DOES NOT CONTACT THE BOTTOM LIP OF THE TRAY, THE REAR CONNECTORS MAY NOT BE FULLY ENGAGED, RESULTING IN POOR OR INTERMITTENT CONTACT.

<p><b>AVIDYNE CORPORATION</b></p> <p><b>EX500 INSTALLATION MECHANICAL</b> <b>MFD, TRAY AND PANEL CUT-OUT</b> <b>DIMENSIONS</b></p>
--

### Appendix D Installation Mechanical: Tray Support Structure Panel

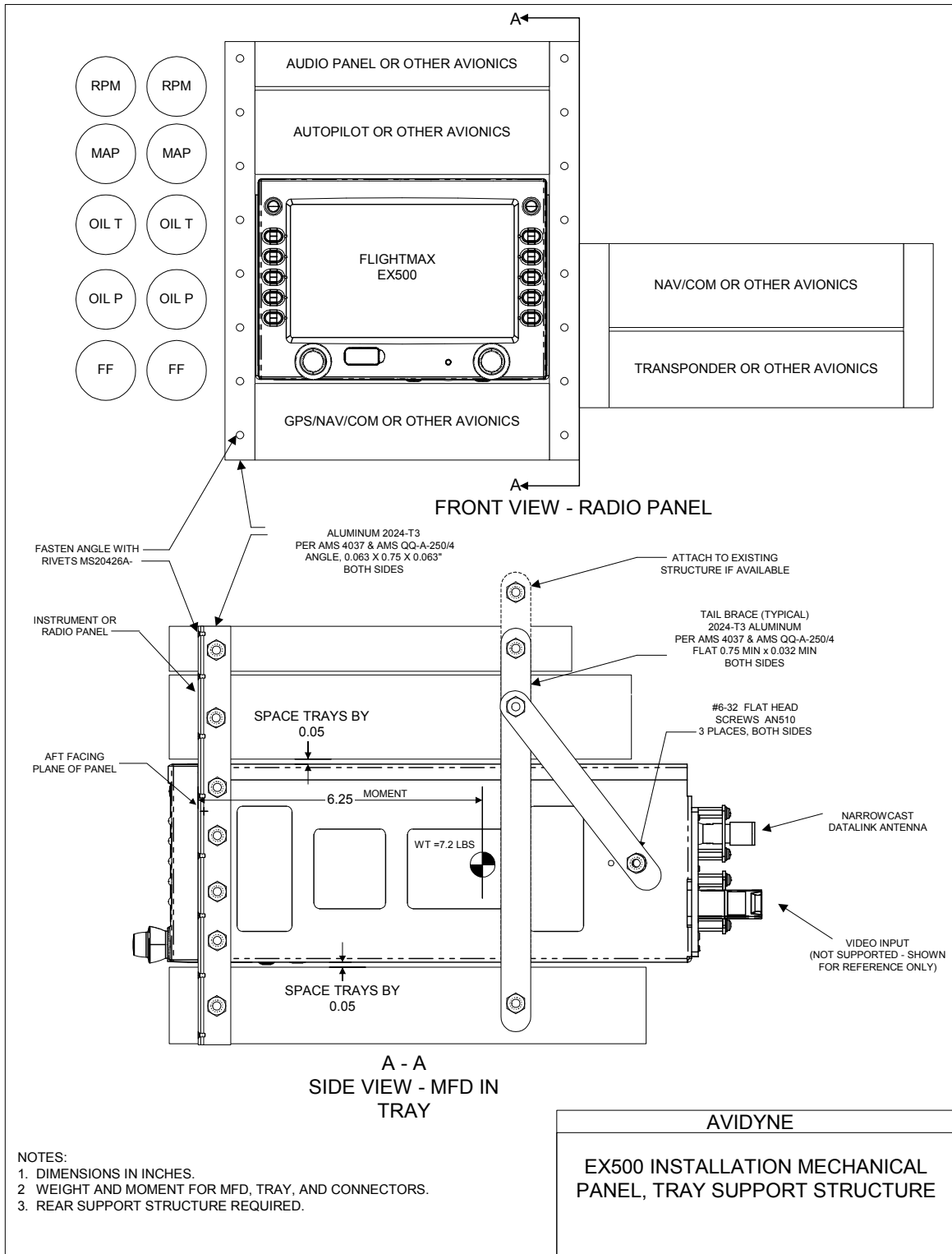



### Appendix E Installation Mechanical: Narrowcast Datalink Antenna

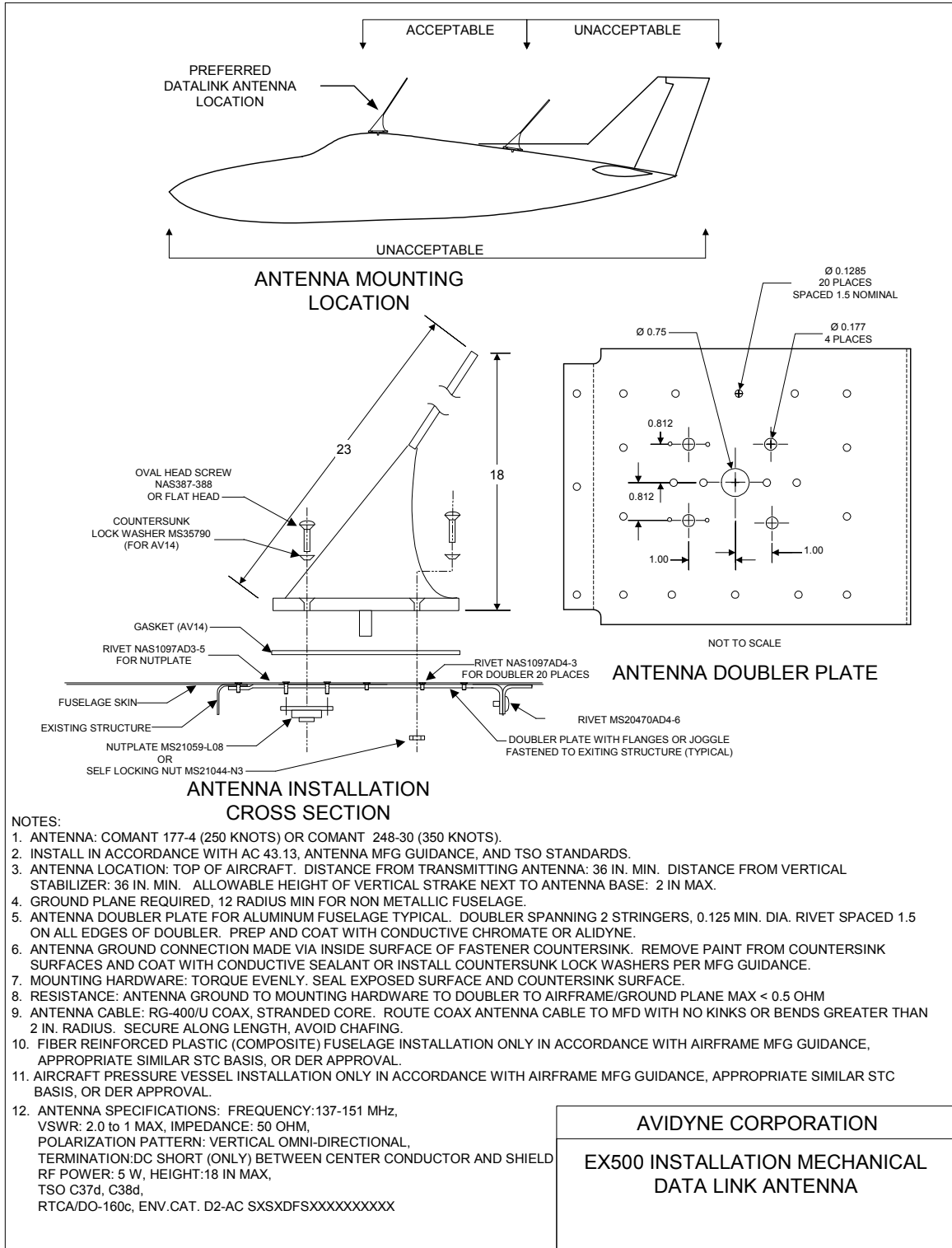

### Appendix F EX500 Wiring: General

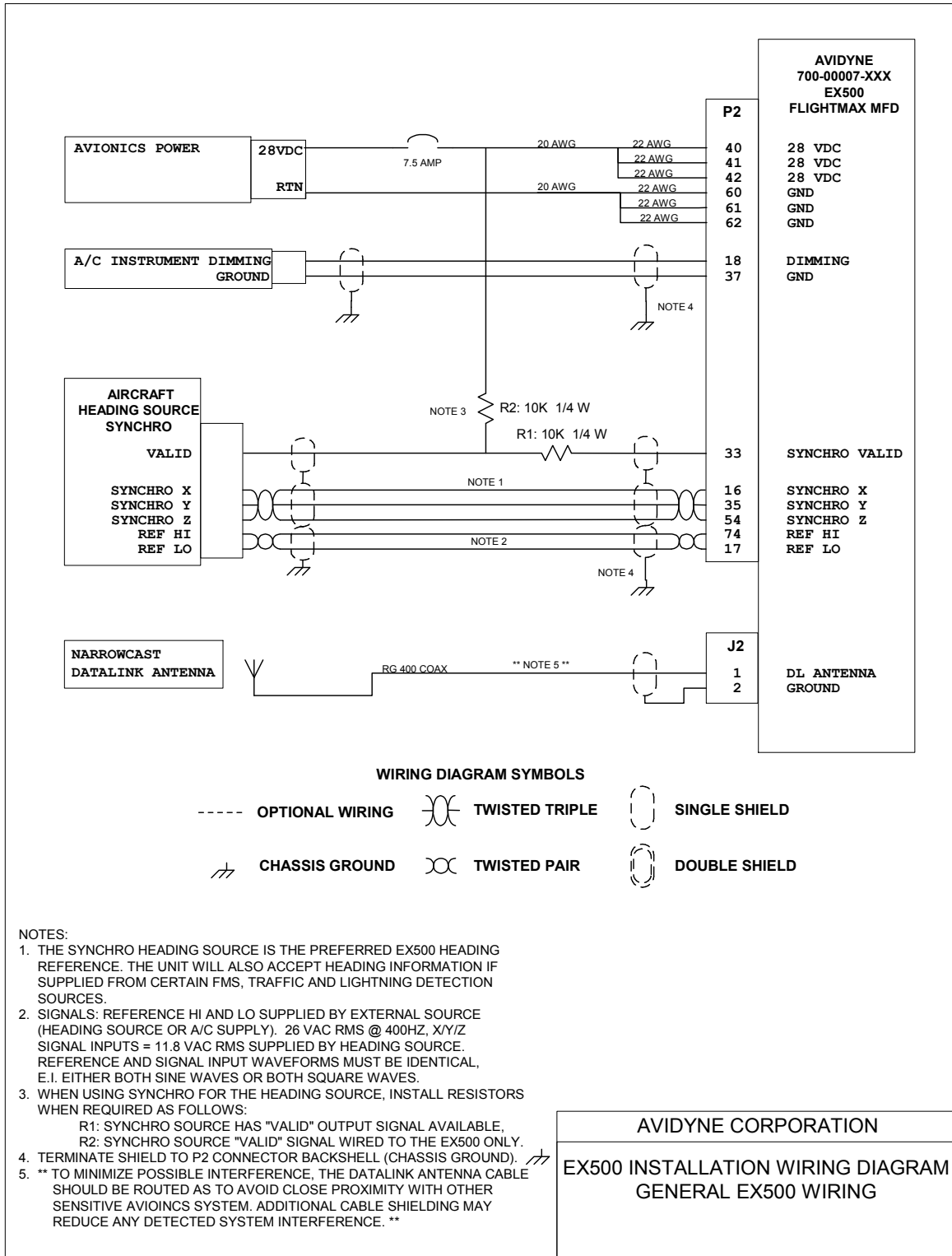

Appendix G EX500 Wiring: GPS/FMS Sub-system

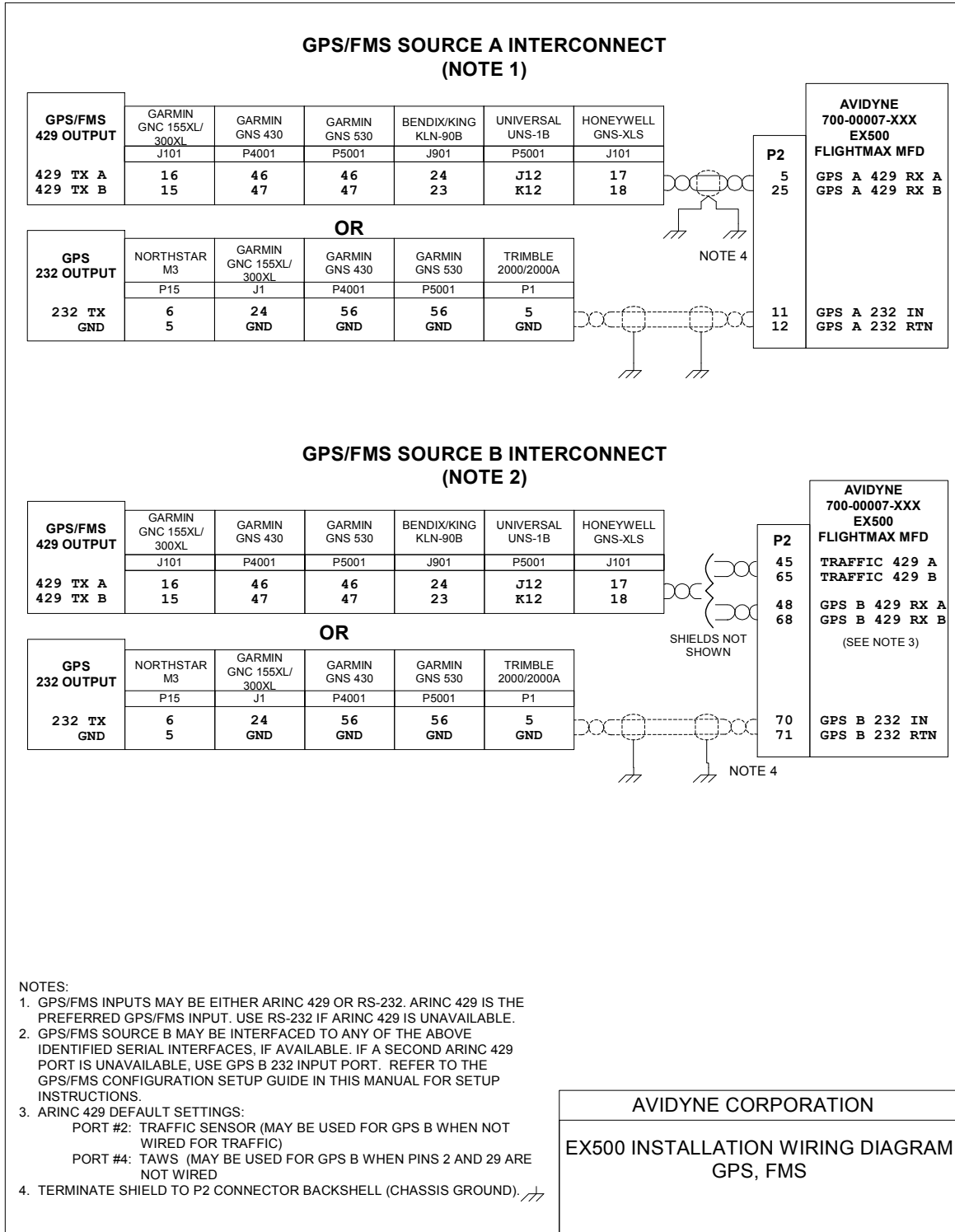

Appendix H EX500 Wiring: Lightning and Broadcast Datalink Sensors

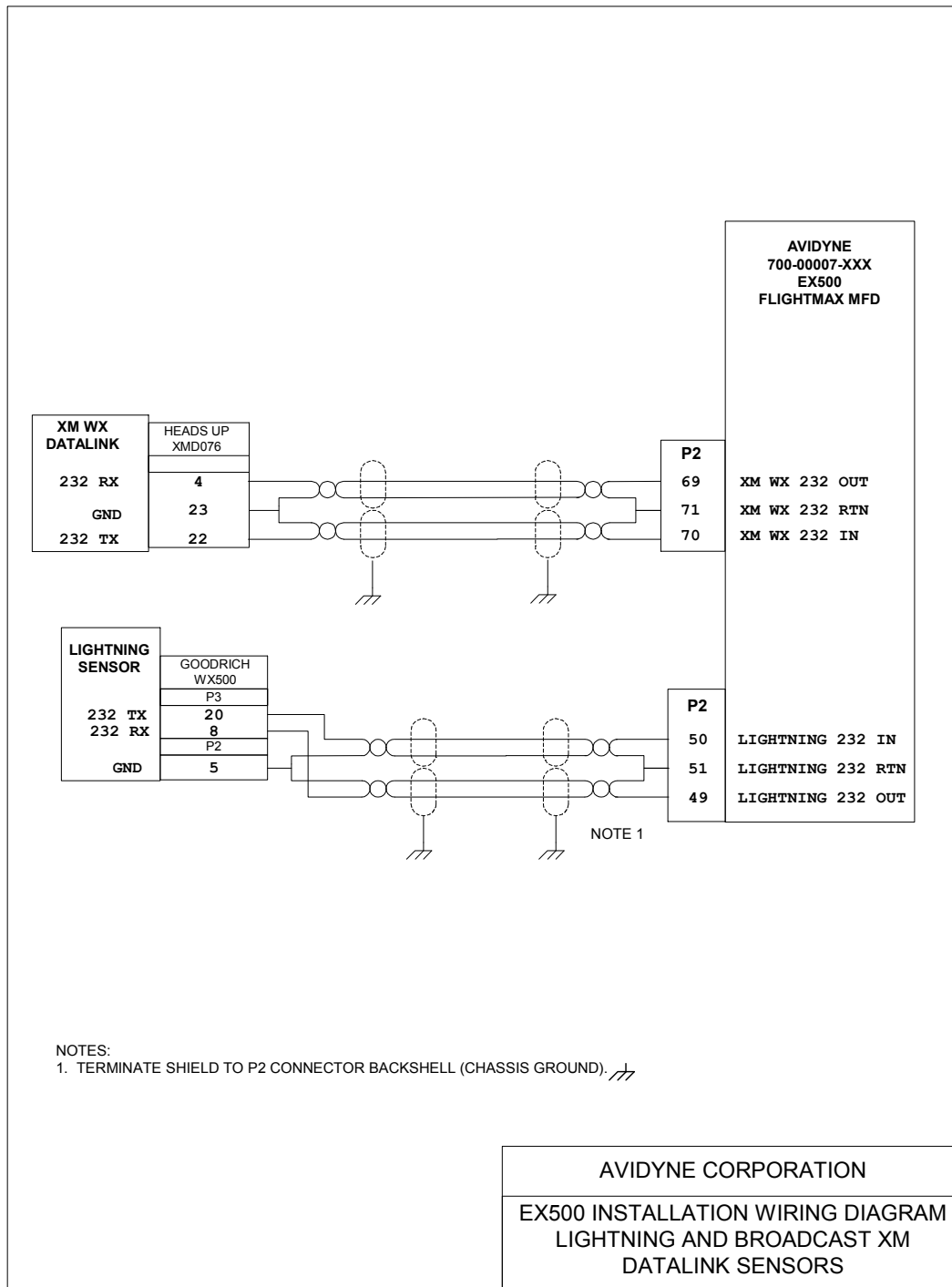

### Appendix I EX500 Wiring: Traffic Sensors

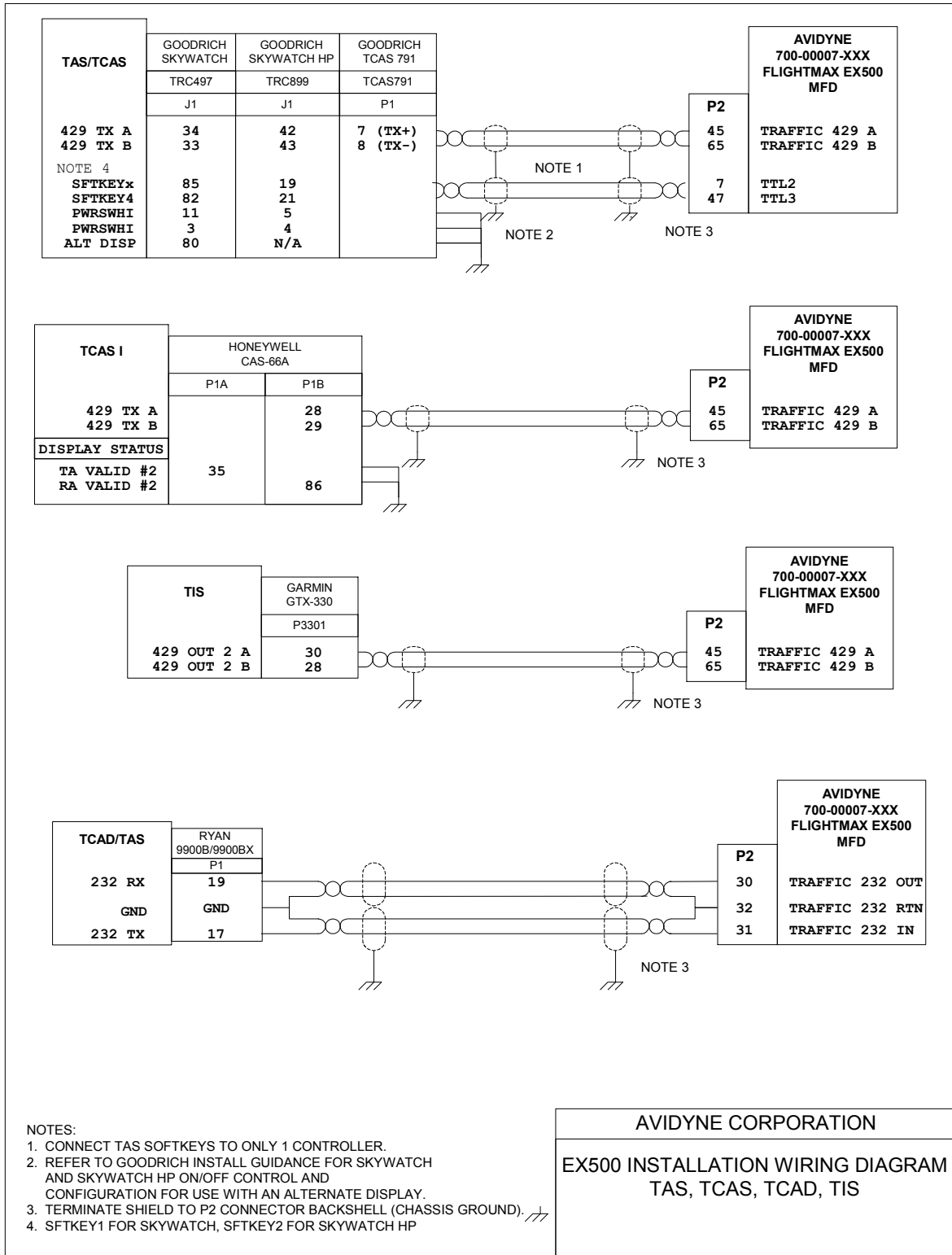

### Appendix J EX500 Wiring: Traffic/TAWS Sensors

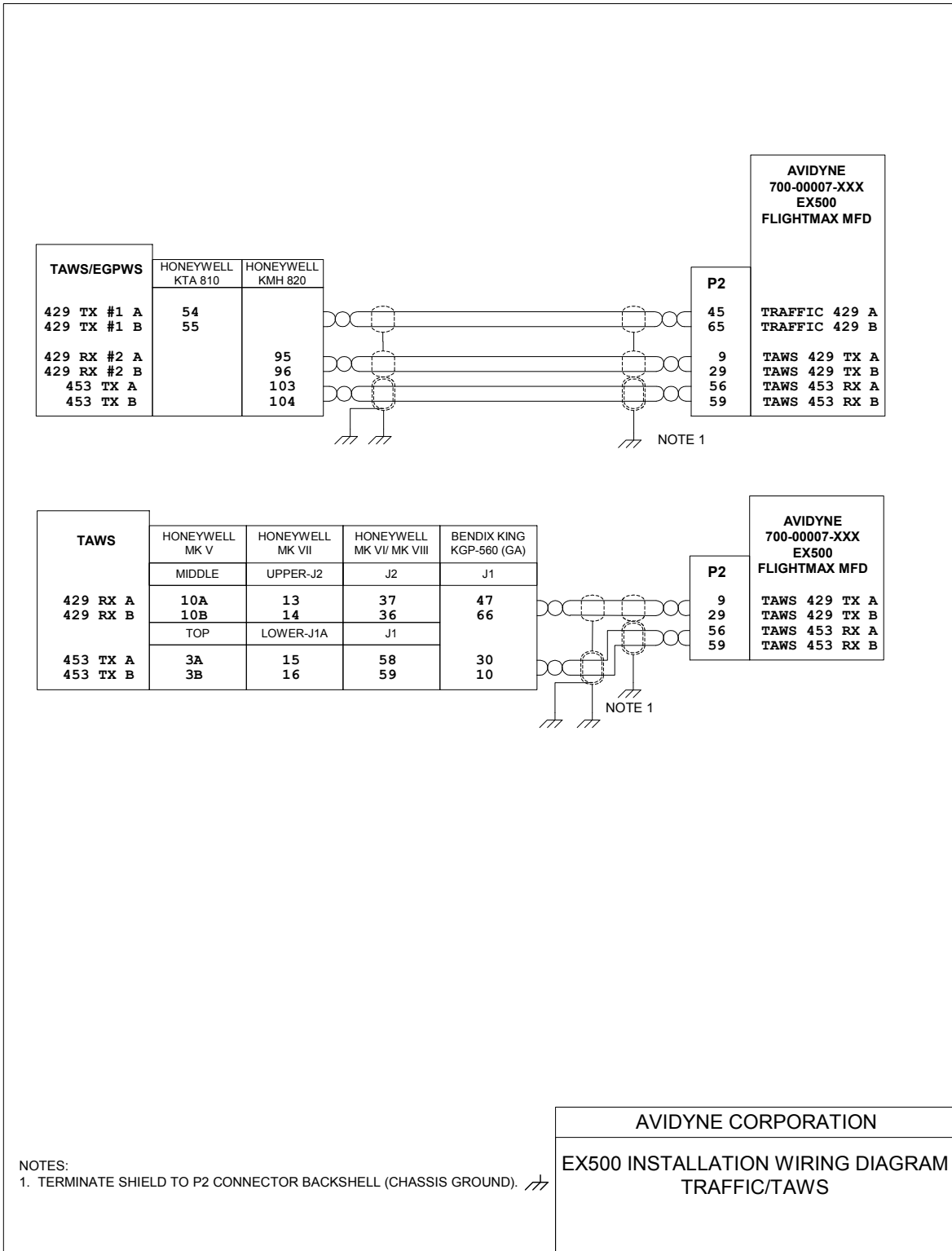

### Appendix K EX500 Wiring: Digital RADAR

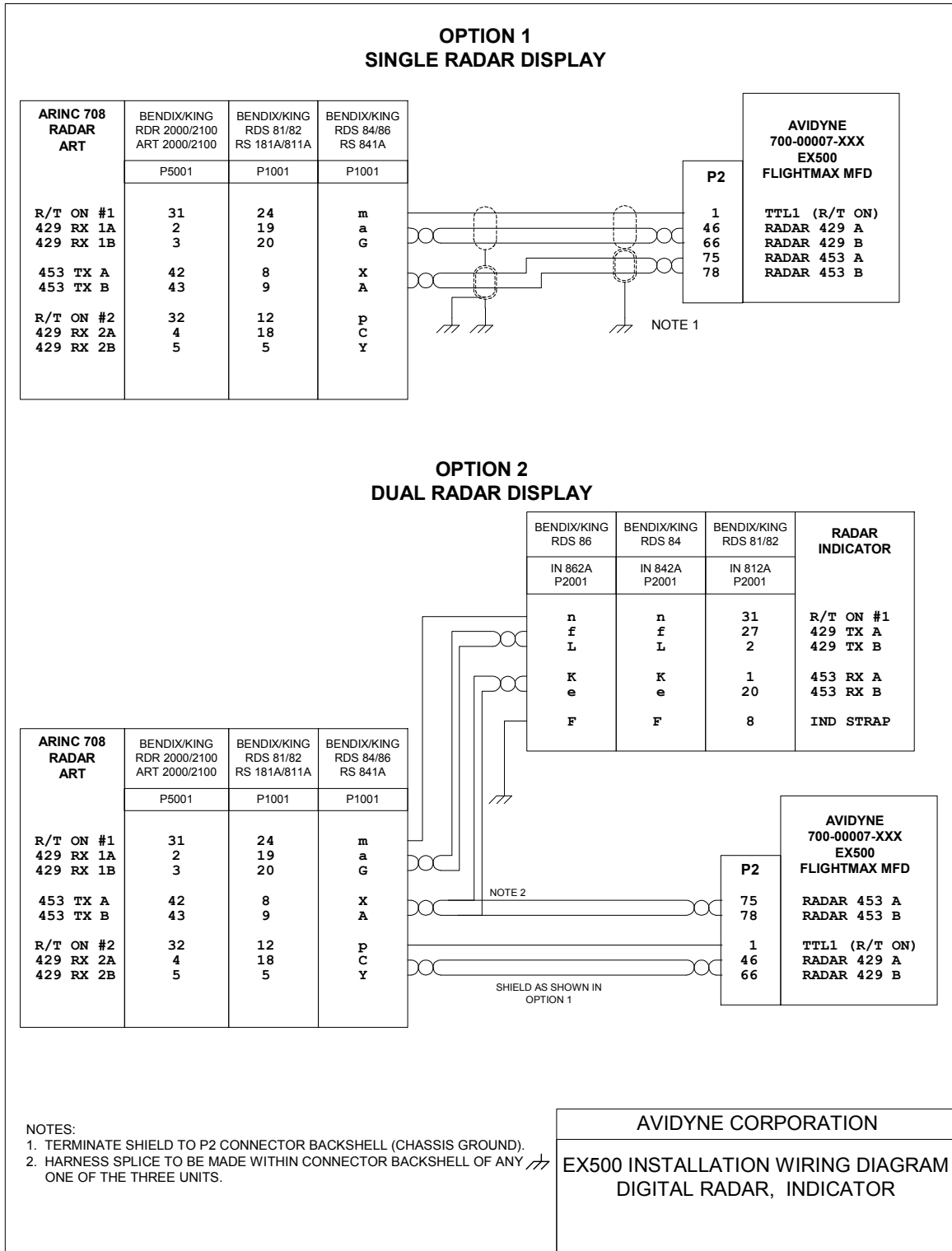





Appendix M EX500 Wiring: RDR-130/150/160 RADAR w/ Adaptor Cable

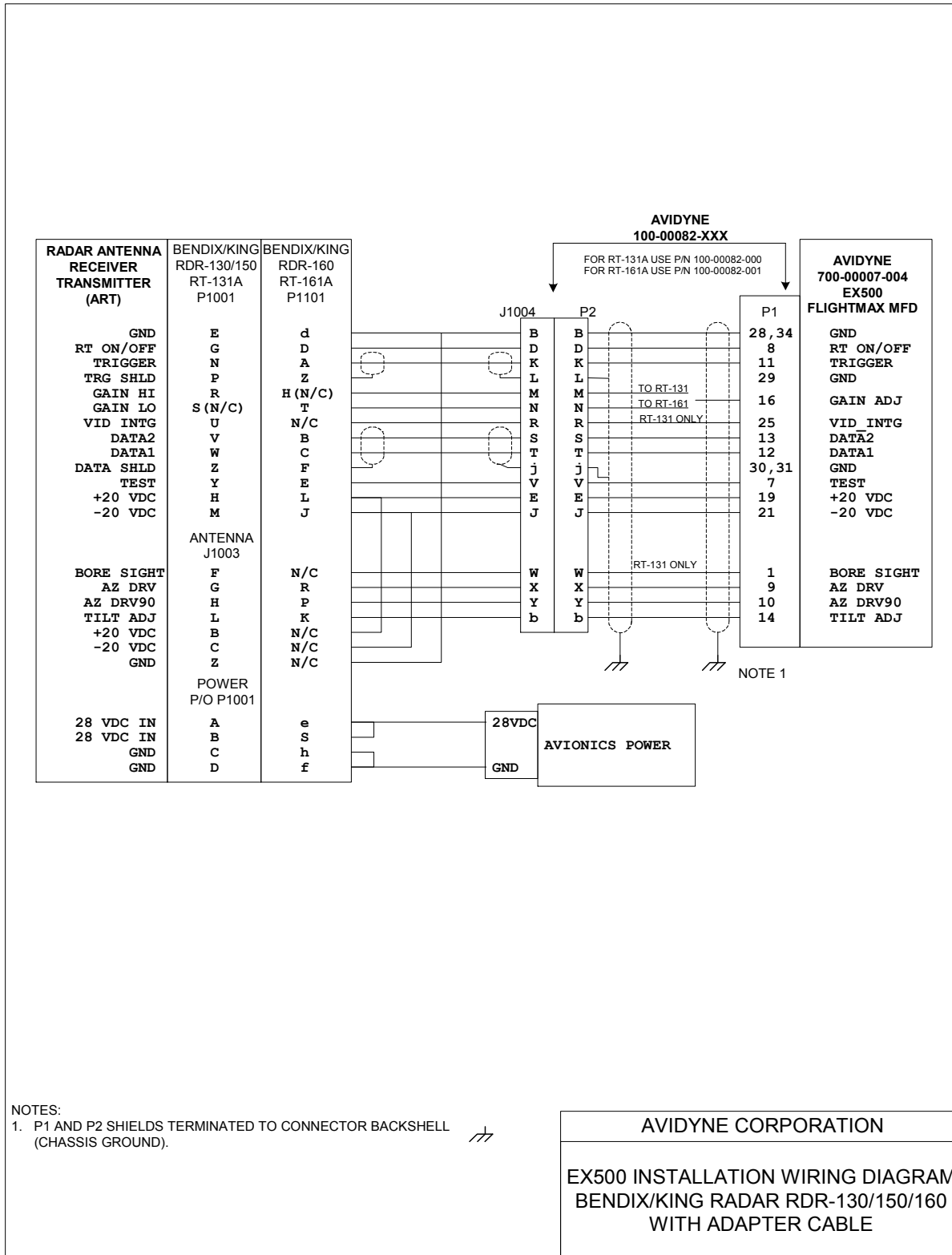

NOTES:

1. P1 AND P2 SHIELDS TERMINATED TO CONNECTOR BACKSHELL (CHASSIS GROUND).

AVIDYNE CORPORATION

EX500 INSTALLATION WIRING DIAGRAM  
BENDIX/KING RADAR RDR-130/150/160  
WITH ADAPTER CABLE





Appendix P EX500 Wiring: RDR-1300 RADAR Direct Connect

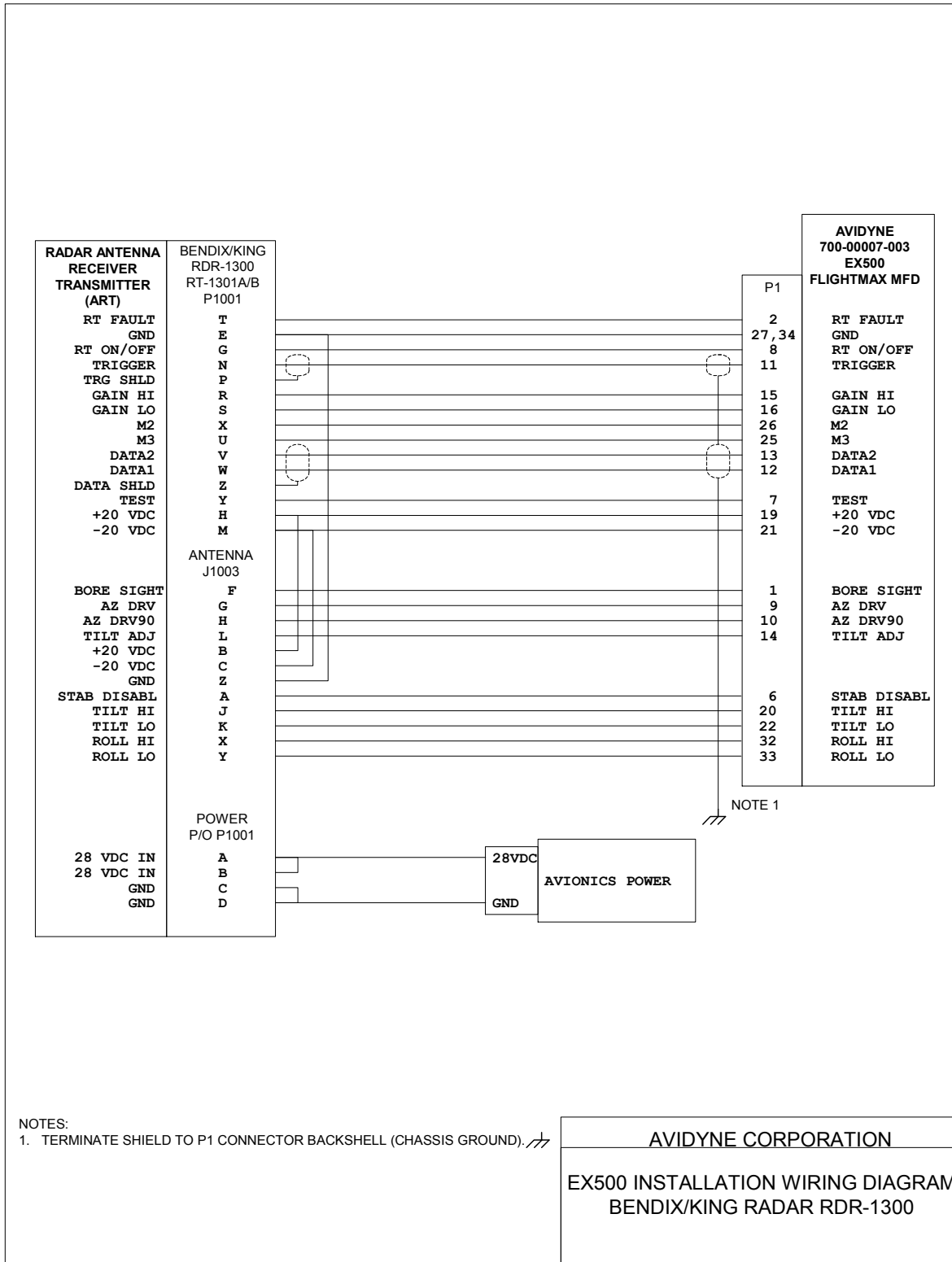

Appendix Q EX500 Wiring: RDR-1300 RADAR w/ Adaptor Cable

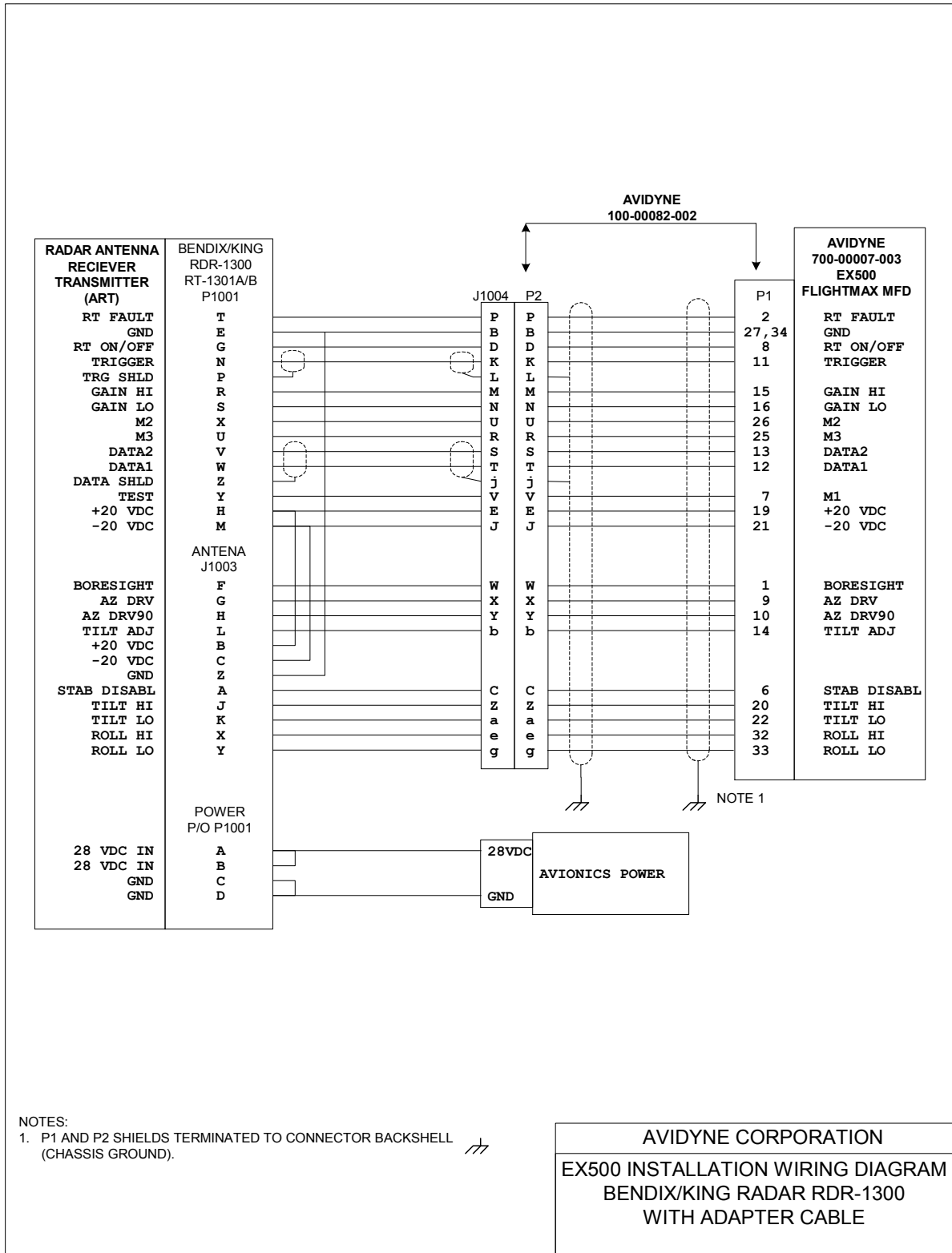

Appendix R EX500 Wiring: WXR250/270/300 RADAR w/ Adaptor Cable

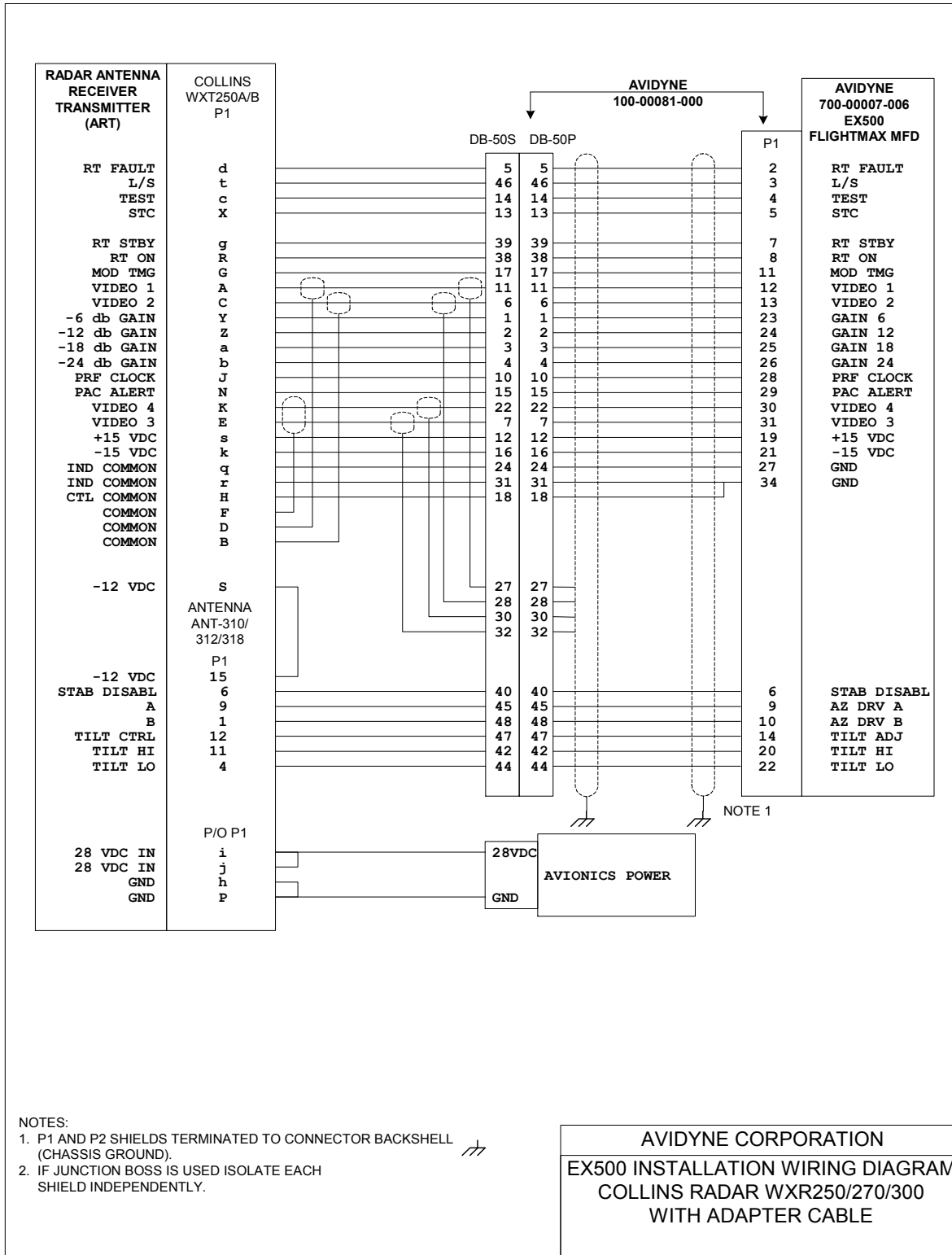

- NOTES:
1. P1 AND P2 SHIELDS TERMINATED TO CONNECTOR BACKSHELL (CHASSIS GROUND).
  2. IF JUNCTION BOSS IS USED ISOLATE EACH SHIELD INDEPENDENTLY.

AVIDYNE CORPORATION  
EX500 INSTALLATION WIRING DIAGRAM  
COLLINS RADAR WXR250/270/300  
WITH ADAPTER CABLE